

# CROSSROADS

An Undergraduate Research Journal of the  
Monmouth University Honors School

Monmouth University  
West Long Branch, New Jersey

*Crossroads* is published annually by the Honors School at Monmouth University. All rights reserved. *Crossroads* is printed in the United States of America. Opinions expressed in the journal are not necessarily the opinions of the Monmouth University Honors School.

The purpose of this journal is to involve students in the creative process of a journal as well as for them to gain professional experience publishing their honors theses and projects.

For a free subscription, contact the Honors School Dean at:

Honors School  
Monmouth University  
431 Cedar Avenue  
West Long Branch, NJ  
07764-1898 U.S.A.

---

## TABLE OF CONTENTS

EDITOR'S NOTE.....	iv
EDITORIAL STAFF .....	v

### ABSTRACTS

[The following abstracts appear in the journal in lieu of the entire articles in order to avoid possible copyright conflicts with the professional journals in which they are being published.]

STUDYING HIF-1 IN THE RAT TESTIS (Biology)	
Preethi Pirlamarla .....	1

THE GABAergic PATHWAY AND PROTEIN QUANTIFICATION IN ALCOHOLIC ADOLESCENT RATS (Biology)	
Timothy Swartz.....	2

### THESES

TRAUMA AND THE NARRATIVE: THE ITALIAN-AMERICAN EVACUATION AND INTERNMENT DURING WORLD WAR II (English and History)	
Alena Competello .....	3

THE SEARCH FOR TRANSCENDENTAL NUMBERS (Mathematics)	
Danielle DePasquale .....	15

THIS SIDE OF PARADISE: A PRE-EXISTENTIALIST STUDY OF SOCIETY AND THE CATHOLIC CHURCH (English)	
Erinn Deignan. ....	52

**TABLE OF CONTENTS (cont.)**

NIHILISM AND EXISTENTIALISM IN CHUCK PALAHNIUK'S *FIGHT CLUB* (English and Philosophy)

Dan Duffy ..... 74

THE MATHEMATICS OF GOOGLE (Mathematics)

Krystle Hinds ..... 101

---

## EDITOR'S NOTE

*Crossroads* is an interdisciplinary, undergraduate research journal published by the Monmouth University Honors School. The contributors are Senior Honors Thesis students whose work is nominated by their Chief Advisors and chosen by the Honors Council as representing the most original, thoroughly researched, and effectively argued theses in their fields.

*Crossroads* is made possible through the support of Monmouth University and the generosity of our benefactor Ms. Jane Freed, class of '81. The articles in this volume include work in the fields of: Biology, Mathematics, History, and English Literature. It is with sincere appreciation that we recognize the invaluable contribution made by the members of the Faculty Honors Council who dedicate an enormous amount of time and scrutiny reading every Honors Thesis Proposal. They include Ms. Jane Freed, Dr. Julius Adekunle, Dr. Mary Kate Azcuy, Dr. Mary Lee Bass, Dr. Kenneth Campbell, Professor Patricia Cresson, Professor Maureen Dorment, Dr. Susan Goulding, Dr. Peter Liu, Dr. Frederick McKittrick, Dr. Kenneth Mitchell, Dr. Joseph Patten, Dr. Alan Schwerin, Dr. Diana Sharpe, and Dr. William Tepfenhart. Deep gratitude is also due to the selfless dedication of faculty fulfilling the roles of Chief Advisor and Second Reader in the various disciplines of this year's contributors. They spend untold hours mentoring the students through their yearlong process of research, writing, and oral defense, especially: Dr. Michael Palladino (Biology) for Preethi Pirlamarla, Dr. Dennis Rhoads (Biology) for Timothy Swartz, Dr. Lisa Vetere (English) for Alena Competello, Dr. David Marshall (Mathematics) for Danielle DePasquale, Dr. Stanley Blair (English) for Erinn Deignan, Dr. David Tietge (English) for Dan Duffy, Dr. Joseph Coyle (Mathematics) for Krystle Hinds, and Dr. Katherine Parkin (History) for Stacey Ciprich.

Additionally, we recognize the initiative and continued support of our early directors: Co-Founder, Dr. William Mitchell, Dr. Saliba Sarsar, Dr. Kenneth Campbell, and Dr. Thomas Pearson.

## EDITORIAL STAFF

Brian Garvey, Ph.D., Dean of The Honors School  
Aimée Babbin, Student Editor

*Director of Student Standards,  
Advising and Services* ..... Reenie Menditto

*Cover Design* ..... Pat Cresson, Art Department

*Layout* ..... Erin Hawk

*Editorial Assistant*..... Erin Hawk

*Published by*..... Monmouth University Honors School

*Printed* ..... Monmouth University Copy Center

---

## STUDYING HIF-1 IN THE RAT TESTIS

Preethi Pirlamarla

### Abstract

Testicular torsion is a debilitating condition that occurs when the spermatic artery twists, restricting oxygen delivery to the testis leading to germ cell-specific damage and cell death. Since transcription factor hypoxia inducible factor-1 (HIF-1) primarily regulates oxygen homeostasis in many tissues, we hypothesize that HIF-1 regulates oxygen-tension in the testis and is a key component activated to minimize the damage of testicular torsion. Active HIF-1 is a heterodimer, containing a hypoxia-dependent  $\alpha$  subunit and a constitutively-expressed  $\beta$  subunit. This study was designed to determine effects of ischemia (I)/ischemia-reperfusion (I/R) on HIF-1 $\alpha$  in the adult rat testis, determine testicular cell types expressing HIF-1 $\alpha$ , and examine mechanisms regulating HIF-1 activation. Unilateral testicular I and I/R were surgically induced by 720° torsion for 1-6h and variable times of reperfusion; nuclear proteins were then analyzed by immunoblotting and immunoprecipitation. Surprisingly, HIF-1 $\alpha$  was found to be abundant and non-ubiquitinated during normoxia, suggesting normoxic activity. Results from immunoblotting and immunocytochemistry experiments showed HIF-1 $\alpha$  localized mainly in Leydig cells. To determine mechanisms of HIF-1 activation, nuclear proteins from freshly cultured Leydig cells, cells cultured at 5% or 21% oxygen, or in 250 $\mu$ M H<sub>2</sub>O<sub>2</sub> underwent immunoblotting. Levels of HIF-1 $\alpha$  in cells cultured in 5% and 21% was significantly reduced compared to levels in fresh Leydig cells. Treating Leydig cells with H<sub>2</sub>O<sub>2</sub> as a source of reactive oxygen species did not increase HIF-1 $\alpha$  levels. Therefore, active HIF-1 $\alpha$  appears to be present during normoxia in Leydig cells, suggesting an important role in testicular oxygen homeostasis.

# THE GABAergic PATHWAY AND PROTEIN QUANTIFICATION IN ALCOHOLIC ADOLESCENT RATS

Timothy Swartz

## Abstract

**Background:** High rates for self-reporting of alcohol use by adolescents have raised concerns over the effects of alcohol on the still developing adolescent brain. The relationship between this use and dependency is punctuated by data suggesting adolescents have four times greater frequency than adults for developing alcoholism. The underlying mechanisms are unknown. Previous work from this lab established an animal model for studying adolescent alcohol dependency. Compared to adults from the Long-Evans (LE) strain and juveniles from the Sprague-Dawley (SD) strain, juvenile LE rats are more prone to developing severe withdrawal symptoms (alcohol dependency) following consumption of an ethanol-containing liquid diet. Additionally, juvenile LE rats show higher baseline anxiety levels, of interest because of the association between anxiety and alcohol use in the human population. The present study focused on the inhibitory neurotransmitter  $\gamma$ -aminobutyric acid (GABA) as one potential target for alcohol in the rat brain. **Protocol:** Juvenile (postnatal 25 days, P25) and adult (P60-120) LE and SD rats were placed on an ethanol-containing liquid diet for 2 to 3 weeks. Age-matched control groups were fed an ethanol-free diet. Rats were sacrificed and a traditional nerve-ending (synaptosome) preparation was obtained from the isolated forebrain through homogenization and differential centrifugation. This fraction was used to measure relative levels of the GABA-synthesizing enzyme (GAD) and GABA receptor alpha subunit (GABAR) expression via western blotting. **Results:** There were no significant differences in GAD expression between strains, between age groups or between control and alcohol-fed rats. Compared to juvenile LE rats, relative expression of GABAR was somewhat higher in adult LE rats but there was no significant difference between strains of juveniles. Alcohol consumption had no significant effect on GABAR expression. **Conclusions:** There are no differences in GAD or GABAR expression that would point to a defect in the forebrain GABA system that can be associated with the increased susceptibility of adolescents to alcohol dependency in this animal model. Alcohol targets several other brain systems and future research should be directed at these.

**TRAUMA AND THE NARRATIVE: THE ITALIAN-  
AMERICAN EVACUATION AND INTERNMENT DURING  
WORLD WAR II**

Alena Competello

Issuing a suitable definition for the word trauma proves a difficult task. The nature of trauma is inherently elusive because it involves the inner workings of the mind and is an extremely personal experience. Trauma does not discriminate and its ability to influence subsequent experiences is palpable. Trauma can have an equally significant effect on the memories surrounding particular events, and the ways in which these experiences are narrated. Great strides in traumatic analysis and theory have been made in recent years. Not surprisingly, the large majority of trauma theory focuses on the narratives of Holocaust survivors. The Holocaust is a well-documented atrocity of human rights and morality. However, there exist equally disturbing wartime activities that remain largely undiscovered in the fog of war.

One such incident is the evacuation and internment of Italian Americans during World War II. Many people are aware of the Japanese internment camps developed by the American government after the attack on Pearl Harbor on December 7, 1941. Books that focus on the internment, such as Prisoners of War treat the similar experience of Italian and German Americans somewhat flippantly, as though their trauma was less significant than that of the Japanese. Barely a paragraph in a book of over 100 pages is relegated to the discussion of the Italian and German American experiences. True, the Japanese were treated with even greater disregard for their civil liberties, yet the indelible effect that evacuation and internment had on the Italian Americans must not be undermined.

Italian immigrants came to the United States in large numbers between 1880 and 1924. Most of the immigrants settled in California. The Italians were the last large immigrant groups to come to the United States prior to World War II. They were also the least assimilated by number. This lack of assimilation and absence of naturalization was an especially harsh mark against the perception of Italian American loyalty to the United States. These uncertainties only exacerbated the animosity the War and Justice Department felt towards the Italian Americans after Pearl Harbor. Government officials became convinced that unnaturalized Italian Americans were loyal to Fascist Italy rather than the United States (Fox 3-7).

The issue of Italian American assimilation is double-sided. Economically and financially, Italian immigrants had assimilated to the culture of the United States. They became successful fisherman, laborers, and shopkeepers. However, many Italian immigrants remained in isolated communities, or "Little Italies." As such, there was no need to learn English,

as all of their friends and neighbors spoke Italian. Many retained old world traditions and values (Fox 24-25).

The fear of fascism among Italian Americans in the United States ran rampant after Pearl Harbor. Suspicion surrounded Italian American newspapers, periodicals, and radio broadcasts. Many Italian Americans initially revered Mussolini because he provided a sense of ethnic identity that was lacking. Mussolini was a beacon of hope for the Italian people. According to Albert Mangiapane, an Italian American interviewed by Stephen Fox for his book, Uncivil Liberties: Italian Americans Under Siege during World War II, Mussolini cleaned up Italy, which was filled with gangs and drugs. Mussolini brought a sense of security to the people of Italy (34). However, Mussolini fell out of favor with Italian Americans after he signed the “Pact of Steel” in May 1939, militarily binding Italy to Hitler (36). Despite the change in sentiment toward Mussolini, Italian Americans were seen as sympathizers after the advent of World War II.

The fear of domestic disloyalty began prior to the attack on Pearl Harbor with the fall of France in June 1940. It was a widely held belief that France and other countries were the victims of Fifth Columnists. Consequently, President Franklin D. Roosevelt transferred the Immigration and Naturalization Service to the Justice Department and Congress passed the Smith Act. The act required all noncitizens ages fourteen and older to be fingerprinted and registered with local post-offices. Immediately following the attack on Pearl Harbor, noncitizens were labeled “enemy aliens,” however, they were not yet treated as a serious threat to national security. On December 8, “dangerous” Italian and German Americans were arrested by government officials. Yet, naturalization was allowed to continue for any noncitizens who had already obtained their first or second papers (Fox 73-74).

By mid-December 1941, the restrictions began. Enemy alien registration and restrictions affected all 600,000 Italian American enemy aliens and their families. After the United States officially entered World War II, notices were posted that required all aliens to apply for a Certificate of Identification at their local post office. Each alien was required to bring a passport-sized photograph. Each was fingerprinted and given a photo-identity card with the title “alien registration certificate” which they were required to carry at all times. A curfew between 8 P.M and 6 A.M. was set and travel was restricted more than five miles from home. Aliens were required to turn over all firearms, cameras, short-wave radios, and signaling devices to the Justice Department. Any changes of residence or employment

had to be reported to the local police (DiStasi 16). The harshest restriction was enacted in late January 1942: eighty-six prohibited and restricted zones were established on the West Coast. The zones were to be cleared of all enemy aliens who would then be relocated east of the Sierra Nevada Mountains (Fox 78). Nearly 10,000 Italian Americans were evacuated and 52,000 were subjected to curfews (DiStasi xviii).

There was some debate among government officials over the relocation of Italian and German Americans on the West Coast, the decision to intern Japanese Americans, on the other hand, was seen as an essential aspect of national security. Attorney General of California Earl Warren was concerned about the repercussions for national unity should the Italian and German Americans be forced to relocate (DiStasi 41). He was fearful of the damage the relocation would have on the economic welfare of California because the Italian fisherman composed eighty percent of the state's fishing business (Fox 85).

The public tide also began to turn on the enemy aliens by the end of January, 1942. On January 25, the Roberts Commission, named after Chief Justice Owen J. Roberts, released its report. The Committee's report hinted that the Japanese Americans in Hawaii had something to do with the attack on Pearl Harbor. The report stressed the necessity of dealing with Axis enemies on the mainland. Four days later, the Justice Department ordered the first relocation. General DeWitt eagerly declared his readiness to take charge of the mass relocation for the Justice Department. However, DeWitt's proposed relocation was riddled with difficulties and improbabilities. Italian and German aliens would be difficult to discriminate from the California population and the number of people involved would prove a task of great magnitude. Secretary of War Stimson recommended to the president that the Italians and Germans be left alone for the time being. However, Attorney General Biddle surrendered his authority to the army and gave the reins over to DeWitt. Biddle's actions persuaded President Roosevelt that the Justice and War Departments were in agreement over the necessity of relocation. On February 19, the president issued Executive Order 9066, which put an end to all wavering over the evacuation question: the order authorized the army to exclude anyone (Italian, German, and Japanese) from the restricted zones along the West Coast (Fox 55-72).

Nearly 10,000 Italian enemy aliens had to move out of prohibited zones in California during February and March, 1942. According to Rose D. Scherini's "When Italian Americans Were 'Enemy Aliens'" when the FBI arrested an enemy alien, it told him and his family that there was a

presidential warrant for his arrest. The alien was then held in a detention facility of the Immigration and Naturalization Service (INS) and then transported to a military camp in an inland state (DiStasi 13). When the relocation began, a congressional committee, called the Tolan Committee, began public hearings into relocation and interment. The Committee published reports of its findings and recommendations. The hearings were designed to evoke sympathy for the Italian Americans and calm the public and congressional fury raging against them (Fox 134). In its preliminary report of March 19, the committee warned that the proposal to relocate the Italian and German communities on the West Coast, nearly ten times larger than those of the Japanese, would be detrimental to any hope of winning the war. As a result of public opinion and the Tolan Committee's findings, Stimson recommended to President Roosevelt that the Italians and Germans not be relocated in the same manner as the Japanese. Roosevelt approved Stimson's recommendation. In October 1942, on Columbus Day, Attorney General Biddle announced that the government would no longer classify Italian Americans as enemy aliens (DiStasi 44-51).

Despite the lifting of the enemy alien stigma, further abuses of Italian American's civil rights continued. Assemblyman Jack Tenney headed the Joint Fact Finding Committee on Un-American Activities. The committee held hearings in San Francisco in May 1942. At these hearings dozens of Italian Americans were accused of being leaders of the West Coast Fascist movement. These men were ordered to leave the state for the duration of the war even though no illegal action had been proved against them and they were all US citizens. They were only allowed to return with many of the internees after the surrender of Italy in 1943 (DiStasi 305).

Although the level of mistreatment inflicted upon the Italian Americans was not as severe as that inflicted upon the Japanese, the evacuation and internment had a traumatic impact on the livelihood of individual Italian Americans and on the culture as a whole. The recollections Italian Americans hold of the evacuation and internment during World War II now functions in the depths of traumatic memory.

Relatively recently, the analysis of traumatic memory has become a topic of intrigue for literary critics. The earliest research on trauma memory has largely been attributed to the work of Sigmund Freud. Many contemporary trauma theorists, especially Cathy Caruth, focus largely on Freud's early contributions. In Unclaimed Experience, Caruth explores Freud's Moses and Monotheism and Beyond the Pleasure Principle. Caruth explains why Sigmund Freud turned to literature to explain traumatic

experience. Caruth asserts that literature and psychoanalysis are both concerned with the relationship between knowing and not knowing. Caruth borrows Freud's interpretation of traumatic experience as put forth in Beyond the Pleasure Principle. According to Freud, trauma is experienced too soon and too unexpectedly to be fully understood by the psyche. It is for this reason that the traumatic event presents itself again and again to the victim's mind, to try to assimilate itself into the person's consciousness (Caruth 3-4). Caruth then moves on to explain the "historical power" of trauma: not only is the experience repeated after it has been forgotten, the trauma is only experienced through this forgetting (17).

The other contemporary forerunner of trauma theory is Dominick LaCapra. LaCapra primarily addresses the problems that trauma and its aftermath pose to historical understanding and representation. Intricately linked with the attempt to document traumatic experiences is the tendency toward transference, in which the researcher identifies with the victim resulting in the loss of objectivity (38-40). LaCapra insists on the importance of objectivity without the loss of empathy, what he calls "empathic unsettlement" (41). Any successful historical representation of trauma must involve the process of working through trauma (42). LaCapra distinguishes between two processes that may be employed by victims of trauma: acting out and working through. One who is acting out trauma conflates the present and the past, in that the trauma is relived, and he or she is unable to come to terms with his/her experiences. On the contrary, one who is working through trauma is able to recall his or her traumatic experiences without getting "stuck" in the past. The person can speak of the past without reliving it, realizing that he or she is living in the here and now and is able to see possibilities for the future (21-22).

Intricately linked to these processes is the distinction between absence and loss. The distinction is not one between binary opposites, however, because the opposite of absence is presence and the opposite of loss is gain. Furthermore, loss is tied to a particular past event and can be narrated. With loss, something of the past always remains. Absence on the other hand is transhistorical, meaning the event is not confined to any specific period of time and can reappear over time in different contexts. Any narrative that revolves around absence can only be abstract (48-49).

Acting out and working through are also linked to certain emotional symptoms that are expressed in the narratives of trauma survivors. Both acting out and working through are related to historical losses. Absence can be worked through only in the sense that one can learn better to live with it

(65). When loss is converted into absence, one faces endless melancholia and impossible mourning. Working through absence is a psychological impossibility (46). If absence is converted into loss, there is hope of overcoming the anxiety associated with absence, and the possibility of mourning is attainable (57). Mourning is a form of working through trauma, and as such, presents the possibility of reengaging in life (66).

Distinguishing between acting out and working through may have cultural as well as social implications for Italian Americans as a people. Those who are traumatized by extreme events may be resistant to working through the trauma. The resistance results from a “fidelity to the trauma” (LaCapra 22). This may be associated with the feeling that working through the trauma is a betrayal to those who fell victim to or are presently consumed by the traumatic event.

The existence of traumatized communities adequately explains phenomenon fidelity to trauma. The theory of the traumatized community is presented by Kai Erikson in “Notes on Trauma and Community” in Cathy Caruth’s Trauma: Explorations in Memory. Erikson attests to the ability of traumatic experience to create a sense of community amongst survivors. In this context, trauma becomes a sociological concept. A traumatized community differs from a collection of traumatized persons, however. The individual wounds combine to form a group culture that is greater than the sum of its parts (Caruth 185). According to Erikson, the shared traumatic experience serves as a common culture and a form of kinship (190). The importance of community to Italian Americans is an essential part of their culture, and as such, the evacuation and interment experiences during World War II served as a form of kinship among Italian Americans on the West Coast.

In their homeland, the Mezzogiorno, Italians residing in areas south and east of Rome who accounted for eighty-five percent of total Italian immigrants to the United States between 1875 and 1920, were strongly tied to the community. These feelings were transplanted to the small communities that they developed after their immigration to America. These communities were commonly known as “Little Italies.” Selecting a neighborhood in which to live was a delicate process for Italian Americans. Italian Americans based their decisions on their desire to remain close to extended family as well as to live among other people of the Mezzogiorno. There were also benefits to maintaining close ties to the surrounding community. Many Italian American communities took the form of mutual aid societies designed to assist families. Italian American families in need received support from

within the Italian American community itself. Along with material and financial support came a sense of morale among the families. These communities fostered the maintenance of old world values in the new world (Gambino 110-111).

Most, if not all, of the analysis of traumatic memory has focused on the experiences of Holocaust survivors. This is not surprising considering that the Holocaust is the most well known and one of, if not the most, distressing event in recent history. What is surprising, however, is how little attention has been paid to the experiences of Italian American internees and evacuees in our own country during World War II. Only recently has sufficient respect been paid to the suffering of these men and women. One explanation for the absence of Italian American internment and evacuation from the records of history is the fact that nearly all of the Italian American enemy aliens did not speak of their ordeals, not even to members of their families. As Velio Alberto Bronzini recalls in his essay “A Market Off Limits” for Lawrence DiStasi’s Una Storia Segreta: The Secret History of Italian American Evacuation and Internment during World War II:

After it was over, it was not talked about much in the Italian community. Until I became aware of the project *Una Storia Segreta*, I had actually put it out of my mind as well. My father and mother didn’t marinate themselves in self-pity, or in ethnic pity (36).

The silence that followed the Italian American internment and evacuation is not surprising when Italian American culture and attitudes are considered. In his book, Blood of My Blood, Richard Gambino provides remarkable insight into the Italian American mentality. Gambino weds personal experience with written records to give the reader an unparalleled view of Italian American culture. Central to the “ideal of manliness” for Italian Americans are: “[h]ard work and self denial [...] firmness of spirit, determination, and the seriousness and probity characteristic of maturity” (130). Also essential is a sense of inner control. In other words, an ideal Italian male asks for nothing and never complains. It cannot come as a surprise therefore, that the men subjected to evacuation and internment chose not to speak of their hardship. Rather, these men bore their burdens on their backs and moved forward with their lives in an effort to regain a sense of self-control. Italian men are also expected to avoid confrontation:

“Therefore, he does not become a representative or a symbol or a spokesman, not even of or for other Italian-Americans” (140). Thus, anything but silence would be deemed antithetical to the Italian American ideal of manliness.

Perhaps another reason why the Italian Americans remained so silent about their ordeal was the shame associated with being stripped of their proudest possessions, their homes and their professions. The government’s establishment of eighty-six restricted and prohibited zones on the West Coast in late January 1940 prevented Italian seamen from boarding their fishing boats docked in the harbors. Italian fishermen were no longer allowed to work. In the Italian America culture, work is tantamount to becoming a man or a woman. Work is considered a matter of pride that is essential to Italian American psychology. Work is so important that, “[i]t is a moral wrong not to be productively occupied” (Gambino 87). For an Italian American, work is life and a fisherman being barred from his boat is tantamount to death.

Another source of pride for Italian Americans is owning property, especially one’s own home. The need to own property is another old world value that was maintained by the Italian immigrants. In the Mezzogiorno, land was an essential part of power because it was the key to all economic success and security. In America, Italian Americans became obsessed with owning their own home or own piece of land (Gambino 140). The evacuation of Italian Americans on the West Coast forcibly removed them from their homes and stripped them of a symbol of their successful transition to the new world and an essential component of pride.

The experience of trauma, at its worst, can mean not only a loss of confidence in the self, but a loss of confidence in the surrounding tissue of family and community, in the structures of human government, in the larger logics by which humankind lives, and in the ways of nature itself, and often [...] in God (Erikson 198).

## Bibliography

- Bosia, Remo. "The General and I." Una Storia Segreta: The Secret History of Italian American Evacuation and Internment during World War II. Ed. Lawrence DiStasi. Berkeley, California: Heyday Books, 2001. 290-302.
- Bronzini, Velio Alberto. "A Market Off Limits." Una Storia Segreta: The Secret History of Italian American Evacuation and Internment during World War II. Ed. Lawrence DiStasi. Berkeley, California: Heyday Books, 2001. 32-36.
- Bruno, Angelina. "What Good Was That?" Una Storia Segreta: the Secret History of Italian American Evacuation and Internment during World War II. Ed. Lawrence DiStasi. Berkeley, California: Heyday Books, 2001. 57.
- Caruth, Cathy. "Recapturing the Past." Introduction. Trauma: Explorations in Memory. Ed. Cathy Caruth. Baltimore: The Johns Hopkins University Press, 1995. 151-157.
- Caruth, Cathy. "Trauma and Experience." Introduction. Trauma: Explorations in Memory. Ed. Cathy Caruth. Baltimore: The Johns Hopkins University Press, 1995. 3-12.
- Caruth, Cathy. "Traumatic Departures: Survival and History in Freud (*Beyond the Pleasure Principle, Moses and Monotheism*)."Unclaimed Experience: Trauma, Narrative, and History. Baltimore: The Johns Hopkins University Press, 1996. 57-72.
- Caruth, Cathy. "The Wound and the Voice." Introduction. Unclaimed Experience: Trauma, Narrative, and History. Baltimore: The Johns Hopkins University Press, 1996.1-9.
- Caruth, Cathy. "Unclaimed Experience: Trauma and the Possibility of History (Freud, *Moses and Monotheism*)."

Unclaimed Experience: Trauma, Narrative, and History.  
Baltimore: The Johns Hopkins University Press, 1996.  
10-24.

Cervetto, Joseph L. "Impersonizing Columbus." Una Storia Segreta: The Secret History of Italian American Evacuation and Internment during World War II. Ed. Lawrence DiStasi. Berkeley, California: Heyday Books, 2001. 266-270.

DiStasi, Lawrence. "A Tale of Two Citizens." Una Storia Segreta: The Secret History of Italian American Evacuation and Internment during World War II. Ed. Lawrence DiStasi. Berkeley, California: Heyday Books, 2001. 137-152.

DiStasi, Lawrence. "How World War II Iced Italian American Culture." Una Storia Segreta: The Secret History of Italian American Evacuation and Internment during World War II. Ed. Lawrence DiStasi. Berkeley, California: Heyday Books, 2001, 303-312.

DiStasi, Lawrence. "Let's Keep Smiling: Conditions of Internment." Una Storia Segreta: The Secret History of Italian American Evacuation and Internment during World War II. Ed. Lawrence DiStasi. Berkeley, California: Heyday Books, 2001: 198-216.

Erikson, Kai. "Notes on Trauma and Community." Trauma: Explorations in Memory. Ed. Cathy Caruth. Baltimore: The Johns Hopkins University Press, 1995. 183-199.

Fox, Stephen. "'He was a stool pigeon:' Neighbor against Neighbor." Uncivil Liberties: Italian Americans Under Siege during World War II. USA: Universal Publishers, 2000. 109-127.

Fox, Stephen. "'Hundreds of thousands of people:' The Government Retreats." Uncivil Liberties: Italian Americans Under Siege during World War II. USA: Universal Publishers, 2000. 157-173.

- Fox, Stephen. “‘Never to be forgotten:’ Reflections on a Historical Event.” Uncivil Liberties: Italian Americans Under Siege during World War II. USA: Universal Publishers, 2000. 221-231.
- Fox, Stephen. “‘One does not melt souls:’ Italian American Assimilation.” Uncivil Liberties: Italian Americans Under Siege during World War II. USA: Universal Publishers, 2000. 1-25.
- Fox, Stephen. “‘There is absolutely going to be discretion:’ In Defense of Italian Americans.” Uncivil Liberties: Italian Americans Under Siege during World War II. USA: Universal Publishers, 2000. 129-156.
- Fox, Stephen. “‘They’ve taken my husband away!’ Individual Internment and Exclusion.” Uncivil Liberties: Italian Americans Under Siege during World War II. USA: Universal Publishers, 2000. 187-219.
- Fox, Stephen. “‘What’ll happen to our papa?’ The Impact of the Restrictions.” Uncivil Liberties: Italian Americans Under Siege during World War II. USA: Universal Publishers, 2000. 73-107.
- Gambino, Richard. Blood of My Blood: The Dilemma of the Italian Americans. Toronto: Guernica, 1974.
- Goldberg, Amos. “Trauma, Narrative, and Two Forms of Death.” Literature and Medicine. 25 (2006): 122-141.
- Greenberg, Judith. “The Echo of Trauma and the Trauma of Echo.” American Imago 55 (1998): 319-347.

**THE SEARCH FOR TRANSCENDENTAL NUMBERS**

Danielle DePasquale

**Table of Contents**

Abstract .....	16
Introduction .....	17
Chapter 1 – History .....	19
1.1 The Classical Greek Constructions .....	19
1.2 The Irrational and Transcendental Numbers .....	21
1.3 We Cannot Square the Circle .....	22
1.4 Transcendental Numbers Abound .....	22
Chapter 2 – Cantor’s Work .....	23
2.1 Counting the Infinite .....	23
2.2 Multiple Infinities .....	29
2.3 Transcendental Numbers Exist .....	36
2.4 Cantor’s Method .....	38
Chapter 3 – Liouville’s Work .....	41
Chapter 4 – Conclusion .....	49
Bibliography .....	50

**Abstract**

Every real number can be classified as either algebraic or transcendental, the most famous of the latter category being the constant  $\pi$ . There are many categories of real numbers. For example, there are rational numbers, irrational numbers, integers, even numbers, and odd numbers to name a few. Mathematicians have only been certain of the existence of transcendental numbers for a little over 150 years, when Joseph Liouville exhibited the first known example in 1844. This example later became known as Liouville's Number.

This paper intends to review some of the history of transcendental numbers, including classical problems dating all the way back to the ancient Greeks and continuing up to the works of George Cantor, Charles Hermite, and Ferdinand von Lindemann in the latter part of the millennium.

The main focus of the second chapter will be the research and work of George Cantor. He was able to prove that the set of transcendental numbers is an infinitely large set. In fact, Cantor showed, in a way that we will make precise, that *most* real numbers are transcendental.

The third chapter includes a discussion of the work of Joseph Liouville. His techniques are then used to provide proofs that specific numbers, defined by infinite sums, are in fact transcendental. We then speculate on some of the requirements for such numbers to be susceptible to Liouville's techniques.

## Introduction

One important aspect of being a mathematician is the ability to classify objects into distinct groups according to properties they might share. This is certainly done in the case that our objects are numbers. There are many different classes of numbers. For example, classifications include the natural numbers, integers, rational numbers, and real numbers. Another specific class of numbers is known as the transcendental numbers. This infinite set of numbers will be explained and dissected later in great detail.

Each group of numbers has specific qualities that define it. The set of natural numbers could be defined as the set of positive real numbers with a zero decimal expansion. They look like this:

$$\mathbb{N} = \{1, 2, 3, 4, 5, 6, 7, \dots\}$$

They are also called the counting numbers. The next set we consider is an expansion of the natural numbers by including all real numbers with all zero decimal expansions. They are known as the integers and look like:

$$\mathbb{Z} = \{\dots, -2, -1, 0, 1, 2, \dots\}$$

The rational numbers are a little more complex. They are defined as ratios of integers:

$$\mathbb{Q} = \left\{ \frac{a}{b} \mid a, b \in \mathbb{Z}, b \neq 0 \right\}.$$

The rational numbers include all the integers plus numbers with repeating decimal expansions. Both the integers and natural numbers can be shown to be a part of the set of rational numbers. For example, the integers in rational form can be defined as:

$$\mathbb{Z} = \left\{ \frac{a}{b} \in \mathbb{Q} : b = 1 \right\}$$

Then the natural numbers in rational form can be written as:

$$\mathbb{N} = \left\{ \frac{a}{b} \in \mathbb{Q} : a > 0, b = 1 \right\}$$

The natural numbers and the integers are both part of the set of rational numbers by making some adjustments to  $a$  and  $b$ . The hardest set to define is known as the real numbers. They can be called “the continuum” or all the points on the “real line.” One definition would be the set of rational numbers together with all other decimal expansions as well. All of these sets contain

unique qualities that define them, and each smaller set is a part of a larger set.

In order to fully classify numbers, many sets can be further separated into different types. The natural numbers can be broken up into prime numbers, composite numbers, and 1. A prime number is a natural number greater than one whose only divisors are one and itself. Some examples of prime numbers are

$$\{2, 3, 5, 7, 11, 13, 17, 19, \dots\}.$$

A composite number is the product of two smaller natural numbers. For example, 8 is the product of 2 and 4. These definitions leave out the number 1, which is why it is in a category all by itself. The natural numbers can also be broken up into odds and evens. An even number is defined as a multiple of two. The set of even numbers looks like:

$$\{2, 4, 6, 8, 10, 12, 14, 16, 18, 20, \dots\}$$

Odds are all the multiples of two minus one. The odds can be written as:

$$\{1, 3, 5, 7, 9, 11, 13, 15, 17, 19, \dots\}$$

This distinction of odd and even can be extended to the set of integers, meaning that each set could also include negative numbers. The integers can be broken up another way too. There are the positives, negatives, and zero. The positive numbers are numbers greater than zero. That set looks like:

$$\{1, 2, 3, 4, 5, 6, 7, 8, 9, 10, \dots\}$$

This is actually the set of natural numbers. The negatives are numbers less than zero. They look like:

$$\{\dots, -10, -9, -8, -7, -6, -5, -4, -3, -2, -1\}$$

The number zero is neither positive nor negative so it has its own category. This positive, negative, zero distinction also applies to the rational numbers and the real numbers.

Another partition of the real numbers is into the rational numbers and the irrational numbers. The irrational numbers are numbers within the set of real numbers that are not rational. For example,  $\sqrt{2}$  is an irrational

number because it can be shown not to fit into the previous formula for defining a rational number. The most important separation for the basis of this paper is the division of the real numbers into the algebraic numbers and the transcendental numbers.

Algebraic numbers are defined as the roots of polynomials with integer coefficients. For example,  $x^2 - 2$  is such a polynomial. Its roots are  $\pm\sqrt{2}$ . Hence  $\sqrt{2}$  is an algebraic number. Mathematicians studied these roots and a natural question arose: Are all real numbers algebraic? The answer was determined to be “no” and thus a new class of numbers was discovered known as the transcendental numbers. Transcendental numbers are defined as numbers that are not algebraic, and they are the subject of this thesis.

## **Chapter 1 – History**

Mathematics is always exploring new ideas and is always moving in new directions. There is always something new to discover or prove. That is how the idea of transcendental numbers came about in the mathematical world. The area of interest changed from algebra in the seventeenth century to analysis in the eighteenth [10]. According to Kline, “by 1700 all of the familiar members of the number system – whole numbers, fractions, irrationals, and negative and complex numbers – were known,” [10]. It was at this time that some mathematicians began to speculate about the existence of numbers which were not algebraic. In actuality, the idea of different types of numbers had been a topic on the minds of mathematicians long before the eighteenth century.

### **1.1 The Classical Greek Constructions**

The ancient Greeks enjoyed working with mathematics and, specifically, geometric shapes. They were particularly interested in what types of geometric objects could be constructed using only a straight edge and a compass. Three famous construction problems came out of this period and remained unsolved for nearly 2000 years [1]. These problems became known as the Classical Problems. The first problem is the problem of “doubling the cube.” A cube of a certain volume is given, and the problem is to construct a cube with exactly double the volume. The second problem is known as “trisecting the angle.” An angle is given, and the problem is to construct an angle whose measure is exactly one third of the original. The last problem was called “squaring the circle.” A circle with a certain area is

given. Then the problem is to construct a square with the same area as the given circle. It remained unknown to the Greeks whether or not these constructions were generally possible [1]. These Classical Problems became areas of interest in the mathematical field, but they remained unanswered for many centuries.

Closely connected with the idea of constructible objects is the concept of a constructible number [1]. They are numbers that can be realized as a constructed length (starting from a given segment of length [1]). For example,  $\sqrt{2}$  is a constructible number. One must draw two line segments of length one unit at a ninety degree angle. The length of the line that connects the two ends is  $\sqrt{2}$ .

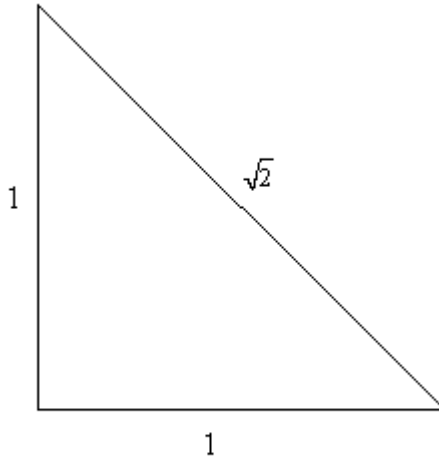

Figure 1.1

These constructible numbers exist within the set of real numbers. The set of real numbers can be broken up many ways which will be better explained in the following chapter. One way is to divide the real numbers into the rational numbers and the irrational numbers. Another, to be discovered later, is the partition into algebraic and transcendental numbers. Their connection to the above Classical construction problems will be made below.



with his proof [11]. Some mathematicians argued that Hermite was the one who should have received more credit, but Lindemann was smart enough to continue what Hermite had failed to do [11].

### 1.3 We Cannot Square the Circle

Let's now turn back to the Classical Problems, specifically, the problem of "squaring the circle." Suppose we start with a circle of radius 1, and therefore with area  $\pi$ . In order to form a square of the same area, a line segment of length  $\sqrt{\pi}$  must be constructed. But this would imply that  $\pi$  is a constructible number. Mathematicians of the nineteenth century had given a complete characterization of the constructible numbers. In particular, they are algebraic! "The construction of a segment of specific length is possible only if that length is a root of a special algebraic equation" [4]. As previously discussed, Lindemann proved that  $\pi$  was not a root of any algebraic equation, i.e. not algebraic. Thus "squaring the circle" is an impossible construction.

### 1.4 Transcendental Numbers Abound

Prior to Lindemann, a mathematician named George Cantor studied transcendental numbers as well. Cantor was interested in the countability of certain sets of numbers. Countable is defined as having the same size as the natural numbers. Cantor was able to prove that the rational numbers and the algebraic numbers were both countable by 1873 [4]. The big step occurred by December 1873 when he proved that the set of real numbers were uncountable. Since the real numbers can be broken up into the algebraic numbers and the transcendental numbers and the algebraic numbers were countable, that meant that the transcendental numbers were uncountable [4]. Cantor proved that "almost all" real numbers are transcendental, not algebraic," [4]. A more in depth explanation of Cantor's proofs is provided in the following chapter.

Mathematicians have not been able to prove the existence of many transcendental numbers. David Hilbert's Seventh Problem involved transcendental numbers. It asked "whether  $\alpha^\beta$  is transcendental for any algebraic number  $\alpha \neq 0,1$  and any algebraic irrational  $\beta$ ," [4]. As it turned out, Aleksandr Osipovich Gelfond and Theodor Schneider were able to prove this theorem by 1934 [4]. Currently, there are still many examples

of numbers whose exact nature is still unknown, including “ $e^e$ ,  $\pi^e$ ,  $2^e$ ,  $\pi^\pi$ , and  $2^\pi$ ,” [4].

## Chapter 2 – Cantor’s Work

### 2.1 Counting the Infinite

Counting is a basic concept of mathematics that everyone is taught when they are young. It enables one to answer the question of how many. We can apply this basic principle to sets. The number of items in a set is known as the set’s cardinality. In finite sets, a set’s cardinality is very easy to determine. For example, let the set A be given

$$A = \{4, 7, 11, 12, 3, 6, 1\}.$$

The cardinality can be easily determined by counting. Thus, the cardinality is seven. Now suppose we have another set, B, which looks like:

$$B = \{16, 10, 22, 41, 5, 8\}.$$

The cardinality here is six. So, obviously, set A is bigger than set B because the cardinality is greater. Counting, as a means to compare the cardinality, however, only applies to finite sets.

The cardinality of infinite sets is a lot more complicated. One might assume that all infinite sets have the same cardinality. In order to make sense of this, one must have a way of comparing infinite sets. We say that two sets have the same cardinality if there exists a one to one correspondence between them [2]. This means that each item in the first set matches to exactly one item in the second set perfectly. For example, take set A and set B again. The cardinality of set A is seven, and the cardinality of set B is six. Now try to set up a one to one correspondence between them.

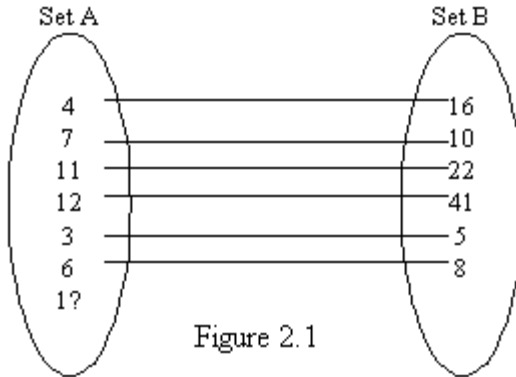

Figure 2.1

As can be seen, there is an extra number in set A that does not correspond to anything in set B. Therefore, there does not exist a one to one correspondence between them. This also proves that they do not have the same cardinality, but that was already known in this finite case. This method becomes more useful in the case of infinite sets. If there is a one to one correspondence between the two sets, then they have the same cardinality.

In order to fully understand the above point, let's look at an example. Take the set of natural numbers

$$\mathbb{N} = \{1, 2, 3, \dots\}.$$

Then compare the natural numbers to a set called C where C is the natural numbers with the number 1 removed.

$$C = \{2, 3, 4, \dots\}$$

Since set C contains one less number than the natural numbers, one would automatically assume they have different cardinalities. This is not the case. Set C and the natural numbers actually have the same cardinality as seen by the one to one correspondence illustrated in Figure 2.2.

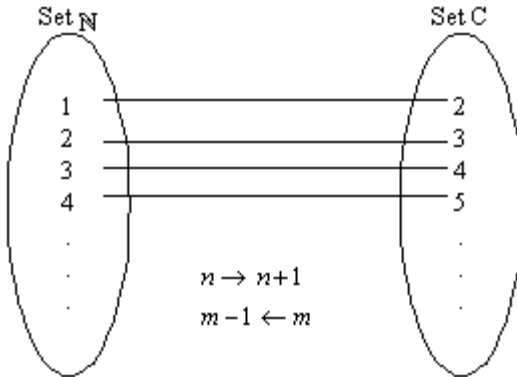

Figure 2.2

One to one correspondences can also be found between the set of natural numbers and the set of odd natural numbers (“the odds”) and the set of even natural numbers (the “evens”). In order to go from the set of natural numbers to the set of evens, a number,  $n$ , must be multiplied by two. Then a number,  $m$ , in the set of evens must be divided by two to get a number in the set of natural numbers. Figure 2.3 illustrates this correspondence.

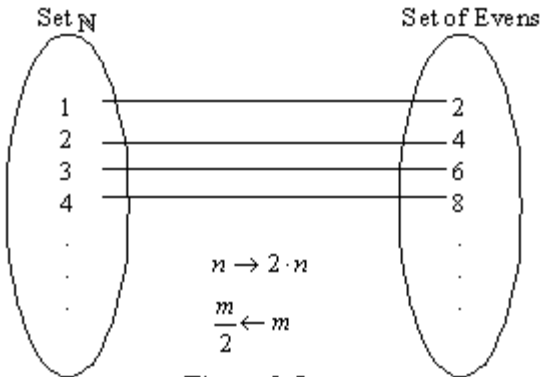

Figure 2.3

The natural numbers can also be compared to the set of odd numbers. The equation that connects the natural numbers to the set of odd numbers involves

multiplying a number,  $n$ , in the set of natural numbers by two and then subtracting one from the outcome. The equation looks like:

$$2 \cdot n - 1$$

In order to complete the one to one correspondence, there has to be an equation going back. In this case, take a number,  $m$  from the set of odds. Then add one to  $m$  and divide the solution by two. That equation looks like:

$$\frac{m+1}{2}$$

Figure 2.4 illustrates this correspondence.

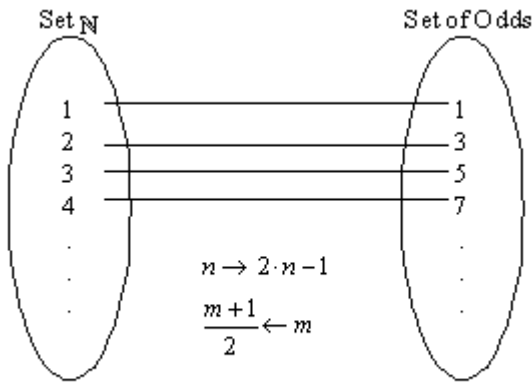

Figure 2.4

So we see that the natural numbers, the evens, and the odds all have the same cardinality. In fact, any infinite subset of the natural numbers will have the same cardinality as the natural numbers.

A countable set is defined as any set with the same cardinality as the natural numbers [2]. As we have seen, some examples of countable sets are the set of odd numbers, the set of even numbers, and the set  $C$  mentioned previously. Another set that is countable is the set of integers. The difficulty in proving countability with the integers is the set is infinite in both the positive and negative directions. In order to fully prove the integers are countable, we will split them in half. The positives together with zero become one subset,  $\varphi_1$ , while the negatives become the other,  $\varphi_2$ . The first goal is to prove that each subset is countable. Then we will prove that the whole set put together is countable. This can be accomplished by comparing the integers to the natural numbers. First, look at the numbers greater than or

equal to zero,  $\varphi_1$ . These can be compared to the set of even numbers. Every number  $x$  within the set  $\varphi_1$  can be multiplied by two. Then add two to the solution to get a number within the set of evens. Since  $\varphi_1$  has the same cardinality as the set of evens, it is countable. Now look at  $\varphi_2$ . This set can be compared to the set of odd numbers. Any number  $z$  in the set of  $\varphi_2$  can be multiplied by negative two. Then one is subtracted from that new number to get a number in the set of odds. This proves  $\varphi_2$  to have the same cardinality as the set of odds and proves  $\varphi_2$  to be countable. The set of odds and the set of evens are both countable sets that are part of a countable set, the natural numbers. This procedure can be extended onto the integers. Since  $\varphi_1$  and  $\varphi_2$  are countable, that means the set that they are a part of must also be countable. Therefore, the integers are countable. Figure 2.5 illustrates this correspondence.

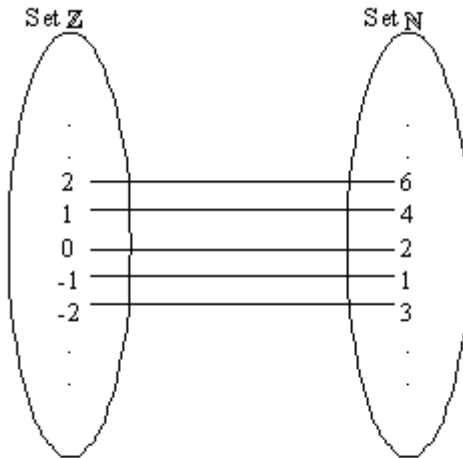

Figure 2.5

The equations defining this correspondence are:

$$\varphi: \mathbf{Z} \rightarrow \square$$

$$\varphi(x) = \begin{cases} \varphi_1(x) = 2 \cdot x + 2 & x \geq 0 \\ \varphi_2(x) = -2 \cdot x - 1 & x < 0 \end{cases}$$

Odds and evens are just two examples of countable sets. The question arises of whether multiples of three are countable as well. The natural numbers can be compared to each subset A, B, and C where they are defined as:

$$A = \{0, 3, 6, 9, 12, \dots\}$$

$$B = \{1, 4, 7, 10, 13, \dots\}$$

$$C = \{2, 5, 8, 11, 14, \dots\}$$

The equation to connect A to the natural numbers is to take a number,  $n$ , in the natural numbers and multiply it by three. To get the set B, every number in the natural numbers is multiplied by three and then one is added to it. For set C, the natural number is also multiplied by three, but two is added to it. Therefore, the multiples of three are countable. This can be applied to any multiple, say  $n$ . The set of multiples of  $n$  looks like:

$$\{n, 2 \cdot n, 3 \cdot n, 4 \cdot n, \dots\}$$

This can be compared to the natural numbers as shown in Figure 2.6.

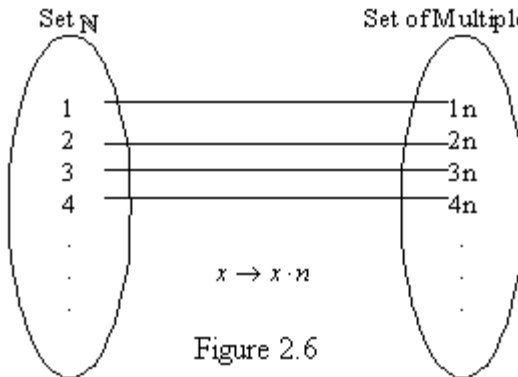

This means that the set of multiples of  $n$  has the same cardinality as the natural numbers and is therefore countable. This gives infinitely many sets that are countable because  $n$  can be any number from one to infinity.

## 2.2 Multiple Infinities

We now wish to determine if the unions of countable sets are countable. First, we'll start with the union of a finite number of countable sets.

**Theorem:** *If  $A_1, A_2, \dots, A_n$  are each countable, then  $A = \bigcup_{i=1}^n A_i$  is countable.*

**Proof:** Without loss of generality, we will assume that each  $A_i$  is infinite and disjoint from all other  $A_j, j \neq i$ . The natural numbers can be broken up into  $n$  infinite sets. The first set will be the multiples of  $n$ . The second set will be the multiples of  $n$  plus one. This will repeat in the pattern that can be seen below.

$$\begin{aligned} \square &= \{n, 2n, 3n, \dots\} \cup \\ &\quad \{n+1, 2n+1, 3n+1, \dots\} \cup \\ &\quad \{n+2, 2n+2, 3n+2, \dots\} \cup \\ &\quad \dots \cup \\ &\quad \{n+(n-1), 2n+(n-1), 3n+(n-1), \dots\} \end{aligned}$$

This now shows that the set of natural numbers can be partitioned into  $n$  infinite subsets. The next step is to relate these subsets back to the set  $A$ . The set  $A$  is already broken up into countable subsets  $A_1, A_2, \dots, A_n$ .

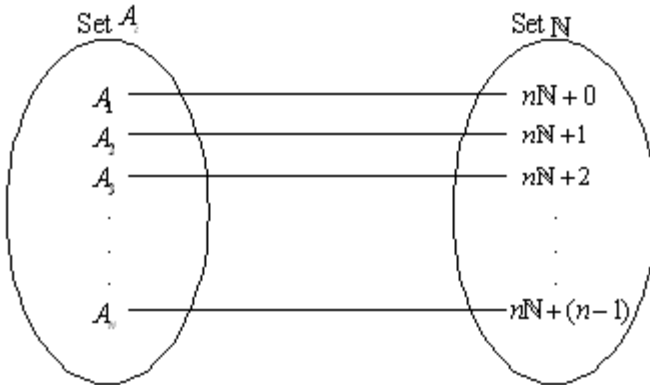

Figure 2.7

Now, we can compare each  $A_i$  to a subset of the natural numbers, as it is shown in Figure 2.7.

Looking at the diagram, there is obviously a correspondence between the set  $A$  and the set of natural numbers. That connection can be viewed as follows:

$$\varphi : A \rightarrow \mathbb{N}$$

$$\varphi_i(x) = \left\{ \begin{array}{ll} \varphi_1(x) & x \in A_1 \\ \varphi_2(x) + 1 & x \in A_2 \\ \varphi_3(x) + 2 & x \in A_3 \\ \cdot & \cdot \\ \cdot & \cdot \\ \cdot & \cdot \\ \varphi_n(x) + (n-1) & x \in A_n \end{array} \right\}$$

where the  $\varphi_i$  are the functions giving the correspondences in Figure 2.7. This shows that there is a one to one correspondence between the set  $A$  and the set  $\mathbb{N}$ . Therefore,  $A$  is countable and the theorem is proved to be true. ♦

This leads to a question. Is every infinite set countable? The answer is no. A set which is not countable is said to be uncountable. One set

that can be proved to be uncountable is the set of real numbers. The proof we give utilizes George Cantor's diagonalization argument (see [2]). Cantor's idea was to show that any countable list of real numbers cannot include all real numbers, and therefore the real numbers are not countable.

**Theorem:** *The set of real numbers is uncountable.*

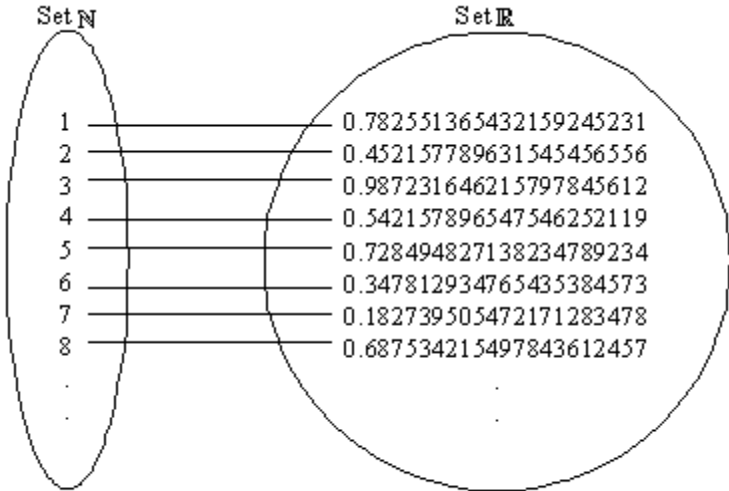

Figure 2.8

**Proof:** Consider any countable list of real numbers. For example, view the list in Figure 2.8. Now we show how to construct a real number that is not on the list. This can be accomplished by constructing our number one decimal place at a time. At each stage, we add an additional decimal digit so as to make sure our number differs from any previous number on the list. I intend to use only the digits 1 and 2. Wherever there is a 1 in the corresponding decimal place of the given real number, we place a 2 into our number. In every other instance a 1 will be placed. For example, in the first real number, since the first digit to the right of the decimal is 7, we place a 1 in our number. Then, since in the second real number the second digit is a 5, we place another 1 in our number.

Natural Number	Real Number	Missing Real Number
1	0.782551365432159245231	0.1
2	0.452157789631545456556	0.11
3	0.987231646215797845612	0.111
4	0.542157896547546252119	0.1112
5	0.728494827138234789234	0.11121
6	0.347812934765435384573	0.111211
7	0.182739505472171283478	0.1112111
8	0.687534215497843612457	0.11121112
9	0.546781246797484246488	0.111211121
10	0.213545879545255545994	0.1112111211
11	0.851315484897124897055	0.11121112111
12	0.012445415489820649431	0.111211121111
13	0.365985200564789646942	0.1112111211111
14	0.789545612054547879990	0.11121112111111

Figure 2.9

Using this method, we will create a real number that is guaranteed not to be on the list of real numbers. This proves that the set of real numbers is not countable and therefore, is uncountable [2]. ♦

The set of real numbers is a very large class of numbers. As mentioned previously in the introduction, the real numbers are all points on the “real line.” One large set contained in the reals is the set of rational numbers. We have proven that the set of real numbers is uncountable. The set of rational numbers is either countable or uncountable. If it is countable, there must exist real numbers that are not rational. We will prove in fact that the rational numbers are countable showing that irrational numbers must exist. First though, we must prove that a union of countably many countable sets is countable.

The union of countably many countable sets is countable is an extension on the fact that finite unions of countable sets are countable.

**Theorem:** *If  $A_1, A_2, \dots$  are each countable, then  $A = \bigcup_{i=1}^{\infty} A_i$  is countable.*

**Proof:** As before, we will assume that each  $A_i$  is infinite and disjoint from all other  $A_j, j \neq i$ .

In order to prove this theorem, we will partition the natural numbers into infinitely many infinite sets. To form the first set in the partition, start with

the number 1. Then to get the next number in the set, you add one to the first number. The second number in the set is two. Now, you add two to the second number to get the third number in the set. In this case, it would be four. To get the fourth number, you add three to the previous term. Therefore, the fourth term would be seven. This is a better depiction of the explanation above. Take the natural numbers.

1 2 3 4 5 6 7 8 9 10 11 12 13 14 15 16 17 18...

The bold underlined numbers are part of the first partition.

**1** ~~2~~ ~~3~~ **4** ~~5~~ ~~6~~ ~~7~~ ~~8~~ ~~9~~ ~~10~~ **11** ~~12~~ ~~13~~ ~~14~~ ~~15~~ **16** ~~17~~ ~~18~~...

In order to determine the second set, you start at the first available number. In this case, it would be three. Then you add two to determine the second number in the set which would be five. Then you add three to determine the third number in the set which would be eight. The second set can be seen below in bold and underline.

~~1~~ ~~2~~ **3** ~~4~~ ~~5~~ ~~6~~ ~~7~~ **8** ~~9~~ ~~10~~ ~~11~~ **12** ~~13~~ ~~14~~ ~~15~~ ~~16~~ **17** ~~18~~...

Now, the third set will start at the next available number which is six. The second number can be found when you add three to the first number. This set can be viewed below in bold and underline.

~~1~~ ~~2~~ ~~3~~ ~~4~~ ~~5~~ **6** ~~7~~ ~~8~~ ~~9~~ ~~10~~ ~~11~~ ~~12~~ **13** ~~14~~ ~~15~~ ~~16~~ ~~17~~ **18**...

Now this process can be repeated to create infinitely many sets that are all infinite in size. So, let's call each set  $B_i$ . The first five sets of  $B$  look like:

$$B_1 = \{1, 2, 4, 7, 11, 16, 22, \dots\}$$

$$B_2 = \{3, 5, 8, 12, 17, 23, \dots\}$$

$$B_3 = \{6, 9, 13, 18, 24, \dots\}$$

$$B_4 = \{10, 14, 19, 25, \dots\}$$

$$B_5 = \{15, 20, 26, \dots\}$$

We need to determine a general form for  $B_k$ . The first number in every  $B_k$  is easy to determine. You simply add up all the numbers starting with  $k$  going back to one.

$$x_1 = 1 + 2 + 3 + \dots + k = \frac{k(k+1)}{2}$$

Then, we have to determine  $x_{n+1}$ . The simplest way to do this is to look at the next few numbers in each set.

$$\begin{aligned}
 x_2 &= x_1 + k \\
 x_3 &= x_2 + (k + 1) \\
 x_4 &= x_3 + (k + 2)
 \end{aligned}$$

which gives the general form

$$x_{n+1} = x_n + (k + n - 1)$$

This is a recursive description. If you wanted to determine the fiftieth number in the first set, you would have to calculate all forty-nine numbers before it. There is a way though to determine the fiftieth digit right in the beginning using an explicit definition. Using a process of back-substitution in the recursive description each  $B_k$  can be determined by using the equation that follows.

$$B_k = \left\{ \begin{array}{l} x_1 = \frac{k(k+1)}{2} \\ x_n = x_1 + (n-1)k + \frac{(n-2)(n-1)}{2} \end{array} \right\}$$

Therefore, one can create infinitely many sets,  $B_i$  that are all infinite and therefore countable. This allows us to compare each  $B_i$  with each  $A_i$  as shown in Figure 2.10.

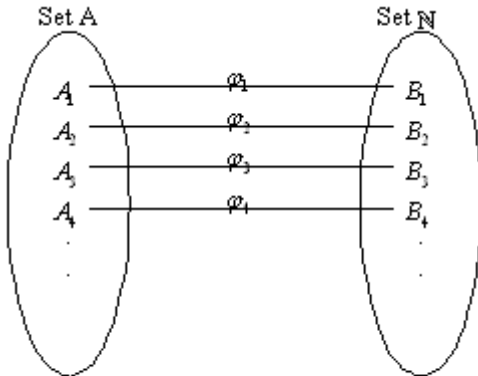

Figure 2.10

Now, we need to prove that the union of all the countable sets is countable. The union of all the  $B$ 's is the natural numbers which are countable. Seeing as each  $A_i$  is comparable to each  $B_k$ , then the entire set of  $A$  is comparable to the entire set of  $B$  which is the set of natural numbers. Therefore,

$A = \bigcup_{i=1}^n A_i$  is countable. So, the union of countably many countable sets is countable. ♦

Now that we know this fact, we can prove that rational numbers are countable. The rational numbers are defined as

$$\mathbb{Q} = \left\{ \frac{a}{b} \mid a, b \in \mathbf{Z}, b \neq 0 \right\}.$$

The first thing to do is to separate the rational numbers into infinitely many subsets. Each subset is obtained by keeping the denominator constant and letting the numerator vary. The division will look like this:

$$\mathbb{Q} = \left\{ \begin{array}{l} \dots \frac{-1}{1}, \frac{0}{1}, \frac{1}{1}, \frac{2}{1}, \dots = A_1 \\ \dots \frac{-1}{2}, \frac{0}{2}, \frac{1}{2}, \frac{2}{2}, \dots = A_2 \\ \dots \frac{-1}{3}, \frac{0}{3}, \frac{1}{3}, \frac{2}{3}, \dots = A_3 \\ \cdot \\ \cdot \\ \cdot \end{array} \right\}$$

Since this is a union of countably many countable sets, the overall set is countable. Therefore, the rational numbers are countable. Since the real numbers are uncountable, there must be another set of real numbers known as the irrational numbers. So, not only have we proved that irrational numbers exist, but we have shown that there are uncountably many of them.

Next we look at the Cartesian product.

**Theorem:** *If  $A$  and  $B$  are countable, then  $A \times B = \{(a, b) \mid a \in A, b \in B\}$  is countable.*

**Proof:** Let  $A = \{a_1, a_2, a_3, \dots\}$  and let  $B = \{b_1, b_2, b_3, \dots\}$ . Now,  $A \times B$  is similar to the set of rational numbers. We can write

$$A \times B = \left\{ \begin{array}{l} (a_1, b_1), (a_1, b_2), (a_1, b_3), \dots = D_1 \\ (a_2, b_1), (a_2, b_2), (a_2, b_3), \dots = D_2 \\ (a_3, b_1), (a_3, b_2), (a_3, b_3), \dots = D_3 \\ \cdot \\ \cdot \\ \cdot \end{array} \right\}$$

Since every  $D_i$  is countable and  $A \times B$  is the union of the  $D_i$ , the entire set of  $A \times B$  is countable. ♦

### 2.3 Transcendental Numbers Exist

Now, let's turn our focus back to the real numbers. A real number is said to be an algebraic number if it is the root of a polynomial with integer coefficients. For example, consider the equation,  $x^2 - 3 = 0$ . The roots are  $\pm\sqrt{3}$ . Those are algebraic numbers. The next question we consider is whether all real numbers are algebraic.

**Theorem:** *The set of polynomials with integer coefficients are countable.*

**Proof:** First we define the set of polynomials with integer coefficients to be

$$\mathbf{Z}[x] = \{P_0 \cup P_1 \cup P_2 \cup \dots\}$$

where  $P_i$  is the set of polynomials of degree  $i$ . That is

$$P_0 = \mathbf{Z}$$

$$P_1 = \{ax + b \mid a, b \in \mathbf{Z}\}$$

$$P_2 = \{ax^2 + bx + c \mid a, b, c \in \mathbf{Z}\}$$

·  
·  
·

Now, each  $P_i$  can be compared to a certain Cartesian product of integers.

$$P_1 \leftrightarrow (a, b) \in \mathbf{Z} \times \mathbf{Z}$$

$$P_2 \leftrightarrow (a, b, c) \in \mathbf{Z} \times \mathbf{Z} \times \mathbf{Z}$$

.

.

.

$$P_n \leftrightarrow (a, b, \dots) \in \mathbf{Z} \times \mathbf{Z} \times \dots \times \mathbf{Z}$$

Then by the Cartesian product theorem that we proved before,  $\mathbf{Z} \times \mathbf{Z}$  is countable because each  $\mathbf{Z}$  is countable. This can be done for each of the  $P_i$ . Then since each  $P_i$  is countable, the union of the countable sets is countable. Therefore, the set of polynomials with integer coefficients is countable. ♦

**Theorem:** *The set of algebraic numbers is countable.*

**Proof:** Since the set of polynomials with integer coefficients is countable, one is able to list them.

$$\mathbf{Z}[x] = \{f_1, f_2, f_3, \dots\}$$

Now, each  $f(x) \in \mathbf{Z}[x]$  has finitely many real roots. The set of algebraic numbers looks like:

$$A = \left\{ \begin{matrix} \text{roots} \\ \text{of } f_1 \end{matrix} \right\} \cup \left\{ \begin{matrix} \text{roots} \\ \text{of } f_2 \end{matrix} \right\} \cup \left\{ \begin{matrix} \text{roots} \\ \text{of } f_3 \end{matrix} \right\} \cup \dots$$

Each set of roots is countable (in fact, finite). Then the algebraic numbers become a countable union of countable sets. Therefore, the set of algebraic numbers is countable. ♦

Just as proving that the rational numbers are countable implied the existence of irrational numbers, proving the algebraic numbers are countable implies the existence of real numbers that are not algebraic. These numbers are known as the transcendental numbers. They are numbers that are not the roots of polynomials. The transcendental numbers are uncountable and are infinitely larger than the infinite set of algebraic numbers. Although most real numbers are transcendental, very few explicit examples are known. A list is displayed in Figure 2.11, reproduced in part from [15], along with the year discovered and mathematician who discovered it.

Number	Year	Mathematician
Liouville's Constant	1850	Liouville
$e$	1873	Hermite
$\pi$	1882	Lindemann
$r(1/4)\pi^{-1/4}$	1959	Davis
$P_7 = 0.4124540336\dots$	1977	Dekking, Allouche, and Shallit
$2^{\sqrt{2}}$	1979	Hardy and Wright
$\sin(1)$	1979	Hardy and Wright
$J_0(1)$	1979	Hardy and Wright
$\ln(2)$	1979	Hardy and Wright
$\ln(3)\text{An}(2)$	1979	Hardy and Wright
$\chi_0^{(4)} = 2.4048255\dots$	1983	Le Lionnais
$r(1/3)$	1983	Le Lionnais
$r(1/6)$	1984	Chudnowsky
$\pi + \ln(2) + \sqrt{2}\ln(3)$	1989	Borwein et al.
$r(1/4)$	1999	Chudnowsky, Walkschmidt, and Nesterenko
$e^{\sqrt{d}}, d \in \mathbb{Z}$	1999	Nesterenko
exponential factorial inverse sum $\dagger$	2003	J. Sondow, pers. comm.

Figure 2.11

Let's look at a simple method in determining transcendental numbers using a technique we have already discussed.

## 2.4 Cantor's Method

George Cantor developed a method of constructing transcendental numbers using his Diagonalization argument [6]. First Cantor determined a way to list all the polynomials with integer coefficients. He decided to use

something called the “height” of the polynomial as a means of ordering them. For example, take the following polynomial.

$$a_0x^k + \dots + a_k$$

The height of this polynomial is given by

$$h = k - 1 + |a_0| + \dots + |a_k|$$

Polynomials of height three are listed below as an illustration.

$$\pm 3x$$

$$\pm 2x \pm 1$$

$$\pm x \pm 2$$

$$\pm 2x^2$$

$$\pm x^2 \pm 1$$

$$\pm x^2 \pm x$$

$$\pm x^3$$

It turns out that there are only finitely many polynomials of any given height. In this fashion, the set of all polynomials can be listed, together with their (finitely many) real roots. The polynomials of heights one through five are listed in figure 2.12. Certain polynomials are omitted for convenience (for example, if they only have rational roots, or if they can be factored). Then the relevant roots,  $\omega_k$ , of each polynomial are determined. Since these numbers provide a list of *all* the algebraic numbers, we can proceed using Cantor’s Diagonalization technique to produce a number not on the list. In this example, only ones and twos are used to create a transcendental number similar to the method of creating another real number using Cantor’s Diagonalization Argument. Figure 2.12 helps to better explain.

$P(x)$	$\omega(k)$	Transcendental
$2 \cdot x$	$\omega_1 = 0.0000000000$	0.2
$x - 1$	$\omega_2 = 1.0000000000$	0.22
$2 \cdot x - 1$	$\omega_3 = 0.5000000000$	0.222
$x - 2$	$\omega_4 = 2.0000000000$	0.2222
$3 \cdot x - 1$	$\omega_5 = 0.3333333333$	0.22222
$x - 3$	$\omega_6 = 3.0000000000$	0.222222
$2 \cdot x^2 - 1$	$\omega_7 = 0.7071067812$	0.2222222
$x^2 - 2$	$\omega_8 = 1.4142135624$	0.22222222
$-x^2 + x + 1$	$\omega_9 = 1.618033989$	0.222222222
$4 \cdot x - 1$	$\omega_{10} = 0.2500000000$	0.2222222222
$3 \cdot x - 2$	$\omega_{11} = 0.6666666666$	0.22222222222
$2 \cdot x - 3$	$\omega_{12} = 1.5000000000$	0.222222222222
$x - 4$	$\omega_{13} = 4.0000000000$	0.2222222222222
$3 \cdot x^2 - 1$	$\omega_{14} = 0.577350269189625$	0.22222222222221
$x^2 - 3$	$\omega_{15} = 1.7320508075688772$	0.222222222222212
$x^2 + 2 \cdot x - 1$	$\omega_{16} = 0.414213562373095048$	0.2222222222222122
$2 \cdot x^3 - 1$	$\omega_{17} = 0.793700525984099737$	0.22222222222221222
$x^3 - 2$	$\omega_{18} = 1.2599210498948731647$	0.222222222222212222
$x^3 + x^2 + 1$	$\omega_{19} = 1.46557123187676802665$	0.2222222222222122222
$x^3 - x^2 + 1$	$\omega_{20} = 0.754877666246692760049$	0.22222222222221222222
$x^3 + x + 1$	$\omega_{21} = 0.6823278038280193273694$	0.222222222222212222222
$x^3 - x + 1$	$\omega_{22} = 1.3247179572447460259609$	0.2222222222222122222222

Figure 2.12

This chart illustrates the creation of a transcendental number one decimal digit at a time. The following chapter will show how to determine in certain cases whether a given number is transcendental.

### Chapter 3 – Liouville’s Work

The question of the existence of transcendental numbers was settled in 1844. In this year, a mathematician named Joseph Liouville constructed a proof of the existence of a transcendental numbers by exhibiting an actual example. This number became known as Liouville’s Number and is given by

$$\sum_{i=1}^{\infty} \frac{1}{10^{n!}} = 0.11000100000000000000000010\dots$$

It was a number specifically designed to use Liouville’s method of determining transcendence. This chapter discusses the work of Liouville and my experimentation related to his work.

“A transcendental number is defined not by what it is but rather by what it is not,” [3]. This means that in order to prove that a number is transcendental, one must prove that the number is not algebraic. Liouville’s Theorem gives a general criterion for showing certain numbers to be transcendental. Both versions of the theorem are shown, but the main one that will be used will be the second one (see [3]).

**Liouville’s Theorem (Version 1):**

*Let  $\alpha$  be an irrational algebraic number of degree  $d$ . Then there exists a positive constant depending only on  $\alpha$ ,  $c = c(\alpha)$ , such that for every rational number  $p/q$ , the inequality*

$$\frac{c}{q^d} \leq \left| \alpha - \frac{p}{q} \right|$$

*is satisfied.*

**Liouville’s Theorem (Version 2):**

*If  $\alpha$  is an irrational number of degree  $d$ , then there are only finitely many*

*$\frac{p}{q}$  such that*

$$\left| \alpha - \frac{p}{q} \right| < \frac{1}{q^d}$$

The basic proof behind these theorems comes from the fact that “algebraic numbers cannot be approximated particularly well by rational numbers having denominators of relatively modest size,” [3]. Liouville determined that there were different types of rational approximations. A “good” rational approximation is quite close to the actual algebraic number, but uses a very

small denominator. A “bad” rational approximation can be close as well, but it uses a very large number in the denominator. Liouville’s Theorem states that algebraic numbers cannot be approximated very well. Liouville exploited this fact and said that if a number can be approximated quite well by a rational number with a small denominator, then the number cannot be algebraic and must therefore be transcendental [3].

Most of my research and experimenting used the contrapositive of Liouville’s Theorem (Version 2).

**Liouville’s Theorem (Contrapositive of Version 2):**

*If  $\alpha$  is irrational and for every natural number,  $d$ , there exists infinitely*

*many  $\frac{p}{q}$  such that,*

$$\left| \alpha - \frac{p}{q} \right| < \frac{1}{q^d}$$

*then  $\alpha$  is transcendental.*

This version can now be used as a test for transcendence. Liouville used this theorem to prove that his specific number, Liouville’s Number, was in fact transcendental. My research works with altering Liouville’s Number and using the Contrapositive of Liouville’s Theorem in order to prove the transcendence of my generated numbers.

I attempted to start simple by changing  $n!$  to  $n^2$ . I wanted to see how much I could slow the growth of the exponent and still remain transcendental..

**Example 1**

Define  $A$  as follows:

$$A = \sum_{n=1}^{\infty} \frac{1}{10^{n^2}}$$

We wish to try and use Liouville’s Theorem to determine whether or not  $A$  is transcendental. Following Liouville’s example, we define

$$R_N = \frac{p_N}{q_N} = \sum_{n=1}^N \frac{1}{10^{n^2}},$$

and so

$$q_N = 10^{N^2}.$$

The  $R_N$  are extremely close approximations to  $A$ , and are our candidate approximations for Liouville's test. The difference between  $A$  and  $R_N$  is given by

$$|A - R_N| = \sum_{n=N+1}^{\infty} \frac{1}{10^{n^2}}$$

For every choice of  $d$ , we wish to show we can find  $N$  such that

$$|A - R_N| < \frac{1}{q_N^d}$$

The left hand side of this inequality looks like this:

$$0.00\dots0010\dots,$$

where the first 1 occurs at the  $(N+1)^2$  place.

The right hand side looks like

$$\frac{1}{10^{d \cdot N^2}} = 0.00\dots001,$$

where the first 1 occurs at the  $d \cdot N^2$  place.

In order to have the left hand side be smaller, we want the following inequality to be satisfied:

$$(N+1)^2 > d \cdot N^2$$

$$N^2 + 2N + 1 > d \cdot N^2$$

But we can pick  $d$  to be any natural number. Picking  $d=3$  gives the inequality

$$N^2 + 2N + 1 > 3N^2 = N^2 + N^2 + N^2$$

which will not be satisfied by any  $N > 2$ . Therefore, we can not conclude that  $A$  is transcendental by using only this method. It is possible that  $A$  is still transcendental, but it is inconclusive. It turns out that the number of zeros between the ones does not increase fast enough in order to make the number susceptible to Liouville's Theorem. I decided to try a slightly faster growing exponent. Instead of using  $n^2$ , we'll try  $2^n$ .

**Example 2**

Define  $A$  as follows:

$$A = \sum_{n=1}^{\infty} \frac{1}{10^{2^n}}$$

Again, we want to use Liouville's Theorem to prove that  $A$  is transcendental.

Using Liouville's example, we define.

$$R_N = \frac{p_N}{q_N} = \sum_{n=1}^N \frac{1}{10^{2^n}}$$

and therefore

$$q_N = 10^{2^N}.$$

The  $R_N$  are extremely close approximations to  $A$  and are the candidate again for Liouville's test. The difference between  $A$  and  $R_N$  is given by

$$|A - R_N| = \sum_{n=N+1}^{\infty} \frac{1}{10^{2^n}}$$

For every choice of  $d$ , we wish to show we can find  $N$  such that

$$|A - R_N| < \frac{1}{q_N^d}$$

The left hand side of this inequality looks like this:

$$0.00\dots001$$

where the first 1 occurs at the  $2^{N+1}$  place.

The right side looks like this:

$$\frac{1}{10^{d \cdot 2^N}} = 0.00\dots001$$

where the first 1 occurs at the  $d \cdot 2^N$  place.

In order to have the left side be smaller, we need the following inequality to be satisfied.

$$2^{N+1} > d \cdot 2^N$$

$$2 \cdot 2^N > d \cdot 2^N$$

Since we can pick  $d$  to be any natural number, we can pick  $d=3$  which gives the following inequality

$$2 \cdot 2^N > 3 \cdot 2^N$$

which will not be satisfied for any  $N$ . Again, we can draw no conclusions about the nature of  $A$ . Of course, that does not mean that the number is not transcendental, it is just inconclusive using Liouville's method. In the next example we try a doubly exponential exponent, namely  $2^{2^n}$ .

**Example 3**

Define  $A$  as follows:

$$A = \sum_{n=1}^{\infty} \frac{1}{10^{2^{2^n}}}$$

We wish to use Liouville's Theorem again to determine whether or not  $A$  is transcendental.

Following Liouville's example, we define

$$R_N = \frac{p_N}{q_N} = \sum_{n=1}^N \frac{1}{10^{2^{2^n}}}$$

and so

$$q_N = 10^{2^{2^N}}.$$

The  $R_N$  are extremely close approximations to  $A$  and are our candidate approximations for Liouville's test. The difference between  $A$  and  $R_N$  is given by

$$|A - R_N| = \sum_{n=N+1}^{\infty} \frac{1}{10^{2^{2^n}}}$$

For every choice of  $d$ , we wish to show we can find  $N$  such that

$$|A - R_N| < \frac{1}{q_N^d}$$

The left hand side of this inequality looks like this:

$$0.00\dots001$$

where the first 1 occurs at the  $2^{2^{N+1}}$  place.

The right side looks like this:

$$\frac{1}{10^{d \cdot 2^{2^N}}} = 0.00\dots001$$

where the first 1 occurs at the  $d \cdot 2^{2^N}$  place.

In order to have the left hand side be smaller, we want the following inequality to hold.

$$2^{2^{N+1}} > d \cdot 2^{2^N}$$

$$2^{2^N} \cdot 2^{2^N} > d \cdot 2^{2^N}$$

In this case, we can pick any fixed number for  $d$  and we will always be able to pick an  $N$  that will make the inequality hold. Therefore,  $A$  is a transcendental number and we have proved the following theorem to be true.

**Theorem:** *The number  $A = \sum_{n=1}^{\infty} \frac{1}{10^{2^{2^n}}}$  is transcendental.*

I did experiment with a few more options, slowing down the growth of the exponent. The next example replaces the exponent  $2^{2^n}$  by  $2^{n^2}$ .

**Example 4**

Define  $A$  as follows:

$$A = \sum_{n=1}^{\infty} \frac{1}{10^{2^{n^2}}}$$

We want to use Liouville's Theorem to determine the transcendence of  $A$ . Following Liouville's example, we define

$$R_N = \frac{p_N}{q_N} = \sum_{n=1}^N \frac{1}{10^{2^{n^2}}}$$

and so

$$q_N = 10^{2^{N^2}}.$$

The  $R_N$  are extremely close approximations to  $A$  and become our candidate approximations for Liouville's test. The difference between  $A$  and  $R_N$  is given by

$$|A - R_N| = \sum_{n=N+1}^{\infty} \frac{1}{10^{2^{n^2}}}$$

For every choice of  $d$ , we wish to show we can find  $N$  such that

$$|A - R_N| < \frac{1}{q_N^d}$$

The left hand side of this inequality looks like this:

0.00...001

where the first 1 occurs at the  $2^{(N+1)^2}$  place.

The right hand side looks like this:

$$\frac{1}{10^{d \cdot 2^{N^2}}} = 0.00\dots001$$

where the first 1 occurs at the  $d \cdot 2^{N^2}$  place.

In order to have the left side be smaller, we want the following inequality to be satisfied.

$$2^{(N+1)^2} > d \cdot 2^{N^2}$$

$$2 \cdot 2^{2 \cdot N} \cdot 2^{N^2} > d \cdot 2^{N^2}$$

In this case, we can pick any fixed number for  $d$  and we will always be able to pick an  $N$  that will make the inequality hold. Therefore,  $A$  is a transcendental number and we have proven the following theorem.

**Theorem:** *The number  $A = \sum_{n=1}^{\infty} \frac{1}{10^{2^{n^2}}}$  is transcendental.*

My next idea for an exponent for the denominator involved a slower growing function. This turns out to be the slowest growing exponent for which I could establish transcendence. I decided to replace  $2^{n^2}$  by  $n^n$ .

**Example 5**

Define  $A$  as follows:

$$A = \sum_{n=1}^{\infty} \frac{1}{10^{n^n}}$$

We want to try and use Liouville's Theorem to determine whether or not  $A$  is transcendental.

Following Liouville's example, we define

$$R_N = \frac{p_N}{q_N} = \sum_{n=1}^N \frac{1}{10^{n^n}}$$

and so

$$p_N = 10^{N^N} \sum_{n=1}^N \frac{1}{10^{n^n}} = R_N q_N.$$

and

$$q_N = 10^{N^N}.$$

The  $R_N$  are extremely close approximations to  $A$  and are our approximations for Liouville's test. The difference between  $A$  and  $R_N$  is given by

$$|A - R_N| = \sum_{n=N+1}^{\infty} \frac{1}{10^{n^n}}$$

For every choice of  $d$ , we wish to show we can find  $N$  such that

$$|A - R_N| < \frac{1}{q_N^d}$$

The left hand side of this inequality looks like this:

$$0.00\dots001$$

where the first 1 occurs at the  $(N + 1)^{N+1}$  place.

The right hand side looks like this:

$$\frac{1}{10^{d \cdot N^N}} = 0.00\dots001$$

where the first 1 occurs at the  $d \cdot N^N$  place.

In order to have the left side be smaller, we want the following inequality to be satisfied.

$$(N + 1)^{N+1} > d \cdot N^N$$

or

$$(N + 1) \cdot (N + 1)^N > d \cdot N^N$$

In this case, we can pick any fixed number for  $d$  and we will always be able to pick an  $N$  that will make the inequality hold. Therefore,  $A$  is a transcendental number and we have proven the following theorem.

**Theorem:** *The number  $A = \sum_{n=1}^{\infty} \frac{1}{10^{n^n}}$  is transcendental.*

All of these proofs enabled me to create an ordered list showing which exponents were susceptible to Liouville's test and which were not. The list is shown below.

$$\frac{1}{10^n}, \frac{1}{10^{n^2}}, \frac{1}{10^{2^n}} \mid \frac{1}{10^{n^n}}, \frac{1}{10^{2^{n^2}}}, \frac{1}{10^{2^{2^n}}}, \frac{1}{10^{n!}}$$

Although this is only a small list, it might be possible to expand on it in order to find the exact point where the exponent becomes susceptible to Liouville's

test. I personally believe that  $10^{n^2}$  is the first place where a transcendental number is created.

#### **Chapter 4 – Conclusion**

The ancient Greeks may have been the first to consider the possibility of different types of numbers such as rational or irrational, as well as constructible numbers. Over the years, many other mathematicians investigated and further developed these ideas. Some examples we are familiar with today include the natural numbers, the rational numbers, the real numbers, the irrational numbers, the algebraic numbers, and finally, the transcendental numbers.

Cantor worked with certain sets, including some of the sets of numbers mentioned above, and proved them to be countable or uncountable. For example, he showed the set of real numbers to be an uncountable set. Cantor was able to prove the existence of the irrational numbers based on the fact that the rational numbers, a countable set, were part of the set of real numbers, an uncountable set. He determined that there were some real numbers that weren't rational based on the fact that the union of two countable sets is countable. He also did this for transcendental and algebraic numbers. Since the set of algebraic numbers, a countable set is a subset of the set of real numbers, he was able to prove not only the existence of transcendental numbers, but that there are uncountably many of them.

Liouville took a different approach to establishing the existence of transcendental numbers by actually constructing a proof for an explicit example. It became known as Liouville's Number. My work included taking Liouville's Number and modifying its exponent in order to prove that the examples I developed were transcendental. After accomplishing this task, I was able to see that my exponents generated an ordering from slowest (growth) to fastest where the faster ones were proved to be transcendental and the slower ones failed. For some future work, I would like to look at this ordering and find the point where numbers switch from being algebraic to transcendental if such a place exists. I would also like to consider using other methods to possibly prove the transcendence of some of the examples we had to leave inconclusive.

## Bibliography

- Bold, Benjamin. *Famous Problems of Geometry and How to Solve Them*. Mineola, New York: Dover Publications, 1969.
- Burger, Edward, and Michael Starbird. *The Heart of Mathematics, An Invitation to Effective Thinking*. Emeryville, California: Key College Publishing, 2000.
- Burger, Edward, and Robert Tubbs. *Making Transcendence Transparent*. New York: Spring, 2004.
- Burton, David. *The History of Mathematics, An Introduction*. New York: McGraw-Hill, 2003.
- Eves, Howard. *An Introduction to the History of Mathematics*. University of Maine: CBS College Publishing, 1983.
- Gary, Robert. "George Cantor and Transcendental Numbers." *American Mathematical Monthly* 101 (1994): 819-832.
- Gelfond, A.O. *Transcendental and Algebraic Numbers*. New York: Dover Publications, Inc. 1960.
- Ginsberg, Brian. "A 'Base' Count of the Rationals." *Mathematics Magazine* 78 (June 2005): 227-228.
- Kempner, Aubrey. "On Transcendental Numbers." *Transactions of the American Mathematical Society* 17 (October 1916): 476-482.
- Kline, Morris. *Mathematical Thought: From Ancient to Modern Times*. New York: Oxford University Press, 1972.
- O'Conner, John J, and Edmund F. Robertson. "The MacTutor History of Mathematics Archive." August 2005. <http://www-groups.dcs.st-and.ac.uk/~history/>.
- Parshin, A.N. and I.R. Shafarevich. *Number Theory IV, Transcendental Numbers*. Germany: Springer, 1998.

Schaaf, William L. *Natural and History of  $\pi$* . US: Leland Stanford Junior University, 1967.

Siegel, Carl Ludwig. *Transcendental Numbers*. Princeton: Princeton University Press, 1949.

Weisstein, Eric W. "Transcendental Number." 1999.  
<http://mathworld.wolfram.com/TranscendentalNumber.html>.

Weisstein, Eric W. "Liouville's Approximation Theorem." 1999.  
<http://mathworld.wolfram.com/LiouvillesApproximationTheorem.html>.

**THIS SIDE OF PARADISE: A PRE-EXISTENTIALIST STUDY  
OF SOCIETY AND THE CATHOLIC CHURCH**

Erinn Deignan

Abstract

One of life's mysteries is the question of the existence of God. The believer cannot prove to the unbeliever that there is a God, and the unbeliever cannot prove to the believer that there is not. Perhaps this is because both proofs rest on the same premise: a belief in the existence of one constant truth. F. Scott Fitzgerald's novel This Side of Paradise explores the existence of this truth and how its absence affects society as a whole. The novel's main character, Amory, is an amalgamation of the ideas of the characters around him. These ideas can be classified into two seemingly diametrically opposed schools of thought: the traditional ideas of the Roman Catholic Church, and the social values of American youth in the nineteen teens. Upon closer examination, the two schools of thought and the characters of which they are composed are more similar than different not because the morals and values of the Church and society are similar, but because in post-World-War-I American society, pure goodness, like pure evil, is hard to find.

Acknowledgements

I would like to thank several people who helped me complete this project. My chief advisor, Dr. Stanley Blair, was truly instrumental in the project. His wisdom and expertise was invaluable to my research. Without him, I doubt my thesis would have been possible. Dr. Vetere, my second reader, was also a great help to me. She allowed me to see my thesis from another's eyes. Most importantly, I would like to thank God for giving me the opportunity to work with so many talented people and to write a thesis that hopefully proves that without Him, life is meaningless.

One of life's mysteries is the question of existence of God. The believer cannot prove to the unbeliever that there is a God, and the unbeliever cannot prove to the believer that there is not. Perhaps this is because both proofs rest on the same premise: a belief in the existence of one constant truth that does not change, regardless of the morals and mandates of society. F. Scott Fitzgerald's novel This Side of Paradise explores the existence of this constant truth and how its absence affects society as a whole through its youth. Through the novel's characters--Amory Blaine, Monsignor Darcy, Alec Connage, Rosalind Connage, and various others—and through Amory's interactions with them, the novel suggests that without a constant truth, one must rely on contingent personal truths that experience reveals to be not truths at all.

Amory is a true amalgamation of the ideas of the characters around him. These ideas can be classified into two seemingly diametrically opposed schools of thought: the traditional ideas of the Roman Catholic Church, and the social values of American youth in the nineteen teens. Upon closer examination, the two schools of thought and the characters of which they are composed are more similar than different not because the morals and values of the Church and society are similar, but because in post-World-War American society, pure goodness, like pure evil, is hard to find.

#### Part I

One of the most complicated and influential characters in This Side of Paradise is Monsignor Darcy because he represents the Roman Catholic Church. Fitzgerald based Darcy's character on an actual priest, Father Sigourney Fay, whom Fitzgerald knew and admired (Piper 37). Like Fay, Fitzgerald once described Darcy as "the most sympathetic character in the novel" (Piper 48). Indeed, Darcy is clearly sympathetic towards Amory. Darcy seems to be a truly admirable priest and the only pure character in the novel. His title alone evokes respect. As a Monsignor in the Catholic Church, he has excelled in matters of faith and doctrine enough so that a title higher than "Reverend," and ironically, even "Father," is warranted. He is a father of fathers and a role model even to his fellow priests. This parallels Darcy's relationship with Amory that represents the larger relationship between the traditional Catholic Church and the new and emerging pre-existential culture of the youth. For Amory, a young man torn between acting on his own whims and following traditional views of life, Monsignor Darcy represents certain aspects of traditional society that remind him of the social structures and requirements that were once so central to American society.

This is particularly important when one considers the time period in which the novel was written. After the Great War, the 1920s were a true time of transition. The traditional ideas and credos that society had formerly followed without question were now being questioned, and in some cases openly rejected by the youth. As stated by Ronald Berman, "The twenties were disintegrative. It was widely recognized that beliefs no longer rested on solid foundations, religious or secular, but novelists dealt necessarily with the nature of beliefs" (1). This is precisely what Fitzgerald does through Monsignor Darcy and Amory Blaine. Amory, as a youth who is influenced by the middle-aged priest, represents the youth at the beginning of the twentieth century. He is engaged in an inner battle to find his identity. Yet, he is confused and unsure of the differing philosophies he is offered and is influenced by both tradition and peer pressure. In contrast, Darcy, who should be steady, constant, and sure of his religious vocation, is really not so different from his young student. Monsignor Darcy's morals and example are not as Christian as they originally seem. Darcy's seemingly pure character is not so pure. Like Amory, Darcy makes mistakes and is unsure of what his purpose and his path in life should be. Although he is more mature than Amory, his character suggests that the solid religious foundations of the past are no longer as solid as they once were.

The first time Amory and Darcy meet, Darcy is described by the narrator as "intensely ritualistic, startlingly dramatic, loved the idea of God enough to be a celibate, and rather liked his neighbor" (Fitzgerald 24). These characteristics make him a sympathetic character both to the reader and to Amory. They characterize Darcy as a priest who is not rigorous or falsely pious and hypocritical. But, perhaps more importantly, they question Darcy's Catholic principles and distinguish him as a priest who follows his own interpretation of Catholicism.

As a man who is "intensely ritualistic," Darcy represents history, specifically the history of the Roman Catholic Church. Until the 1960s and the Second Vatican Council, the Church had perhaps been one of the only institutions in modern society which had not dramatically changed with the times. As a priest, Darcy represents that constant institution that represents tradition, order, and constancy. Because of his title and position, Darcy reminds Amory that structure, religion, and more specifically, Catholicism, even if it is Darcy's own version of Catholicism, have a place in society.

In one of the most telling lines in this passage, the narrator then describes Darcy as a man who "loved the idea of God enough to be a celibate" (Fitzgerald 24). This statement is diametrically opposed to Jesus'

commandment given in the Bible. St. Matthew relates, “Jesus said to him: *Thou shalt love the Lord thy God with thy whole heart and with thy whole soul and with thy whole mind*” (Matthew.2.37). Jesus did not say that Christians are bound simply to love the idea of God, but rather that they are bound to love God Himself with their entire being. The way the narrator relates that Darcy interprets the greatest commandment Jesus gives his followers is quite significant to his character. Darcy is described not as loving God Himself, but rather the idea of God. Darcy thinks and loves in ideas rather than in absolutes. The narrator does not state that Darcy loves God, which is an absolute statement; the narrator states that Darcy loves the *idea* of God. Loving an idea is not the same as loving of God. In fact, loving the idea of God allows for the possibility that there is no God, but rather only an idea. Such thinking seems at least unusual, and perhaps even hypocritical, for a Catholic priest.

Similarly, Darcy does not love his neighbors; instead, he “rather liked his neighbor” (Fitzgerald 24). Darcy’s inability to willfully love others proves his partial lack of faith. According to the Bible, “And the second is like to this: *Thou shalt love your neighbor as thyself*” (Matt.22.39). Clearly, Christ does not say, “thou shalt like thy neighbor.” Once again, this is an example of how Darcy’s version of Catholicism differs dramatically from Christ’s version of the same religion. Therefore, Darcy is not a pure Catholic, which makes him more appealing to Amory, and subsequently to the reader. Joan Allen concurs:

Amory observed that Darcy’s faith had wavered at times, and this was both inexplicable and unforgivable to him. He concluded that this priest was not essentially older than he, and he was just a little wiser and somewhat purer. (70)

Darcy’s like, rather than love of others is a belief that influences his congregation. This is most evident at his funeral, when the narrator states:

All these people grieved because they had to some extent depended on Monsignor. [...] These people had leaned on Monsignor’s faith, his way of finding cheer, of making religion a thing of lights and shadows, making all light and shadow merely aspects of God. People felt safe when he was near (Fitzgerald 266).

Darcy is needed by others because he fills in them a void, yet it is a human void he fills--the human need to be liked. Unlike a priest, who meets the spiritual needs of his people, Darcy meets their human needs. In the way

he explained the faith to others, Darcy showed them that he and God liked them. Therefore, when he dies, the people feel lost because Darcy's diluted version of Catholicism made it seem easier to practice. He was not a saint and did not preach the values of one.

However, Darcy's partial lack of faith, although it draws Amory and Darcy together, also pulls them apart. Amory cannot think of Monsignor Darcy as a flawless father because he knows he is not. Amory begins to doubt Monsignor Darcy's faith as early as their first meeting: the narrator states that Darcy treated Amory "as a contemporary" (Fitzgerald 26). When a Catholic priest, nay, a Catholic Monsignor treats a fifteen-year-old young man as a contemporary, he is unlikely to be functioning as a role model. As the relationship progresses, Darcy continues to treat Amory as a contemporary rather than a young man who is ignorant and in need of guidance. By constantly writing and speaking to Amory by using words such as "you and me" and "we," Darcy further discredits his knowledge and experience by grouping the two of them together as peers (Fitzgerald 157-158). Moreover, Darcy speaks to Amory of his own personal flaws: "I can do the one hundred things beyond the next thing, but I stub my toe on that, just as you stubbed your toe on mathematics" (103). Although this method of treating Amory causes him to like Darcy, and certainly makes Darcy a sympathetic to Amory, it does not characterize Darcy as a sage of wisdom or a paradigm of virtue. Rather, it characterizes him, in Amory's view, as a man very similar to himself.

Perhaps this is exactly what Darcy wants. Thomas Stavola describes Darcy's relationship to Amory in this way: "At best he thinks of himself as a loving but fallible catalytic guide. He is more interested in Amory finding his own identity." (86) Darcy's relationship to Amory is defined through these terms. Darcy does not wish to impose his beliefs or his religion on Amory; rather he wants Amory to find his own way in life, to find himself through the human experience. He wishes to serve as almost a peer mentor for Amory. Moreover, he is willing to accept Amory's mistakes and admit his own. These aspects of Darcy's character make him both a strong and a weak guide for Amory. As a man who makes mistakes, Darcy redefines himself as a human being, and even as Amory's contemporary. Because he admits his failures willingly to Amory, Amory is able to have a much closer relationship with him. However, Darcy's admission of mistakes also makes Amory lose a certain respect for him. Their relationship is such that Amory treats Darcy as a contemporary despite their distinct age difference and Darcy's position in society because Darcy sets the precedent. Through his decision to treat

Amory as an equal, Darcy equates himself with Amory, as well as with his friends.

This Side of Paradise suggests the relationship of the Catholic Church to society through Monsignor Darcy's attempted mentorship of Amory. Through their dialogues and Amory's later response to them, the novel presents a test of morality in which Amory is given moral dilemmas and asked to choose between Darcy's version of Catholicism and his peers' philosophies. His choices are often a convoluted combination of what Darcy's version of Catholicism mandates and of his friends' credos. Darcy identifies this when he writes to Amory and says, "curiously alike we are...curiously unlike" (Fitzgerald 160). Darcy recognizes Amory's half-hearted devotion to him. Even so, Darcy has a definite influence over his young pupil.

Perhaps Darcy's influence on Amory is most significant after his death when Amory is speaking to Mr. Ferrenby, Jesse Ferrenby's father about the importance of socialism. As C. W. E. Bigsby puts it, "The conversion of ... [Amory] to a naïve socialism had had less to do with genuine political persuasion than with [a society] which polarized around wealth and poverty, purity and corruption, youth and age" (88). Amory's belief in socialism is not grounded in conviction. Instead, it is comparable to Darcy's love of the "idea of God." Just as Darcy is in love with ideas, Amory, in imitation of his mentor, defends and loves ideas with gusto. Like Darcy, or perhaps in imitation of him, Amory is not yet sure of his beliefs, morals, or values, and is a man whose convictions falter easily.

Darcy once says to Amory:

People like us can't adopt whole theories, as you did. If we can do the next thing, and have an hour a day to think in, we can accomplish marvels, but as far as any high-handed scheme of blind dominance is concerned—we'd just make asses of ourselves (Fitzgerald 103).

Amory, when arguing for socialism with Mr. Ferrenby, is merely following Darcy's advice. He is engaging in a daily hour of thought, without adopting the theory for which he is arguing. Furthermore, Amory refuses to dominate Mr. Ferrenby or force him to agree with his propositions. He merely discusses the topic with him, and in doing so, he follows Darcy's advice to the letter.

After discussing socialism, a Darcy-esque topic in itself, the narrator states in relationship to Amory:

The idea was strong in him that there was a certain intrinsic lack in those to whom orthodox religion was necessary, and religion to Amory meant the Church of Rome. Quite conceivably it was an empty ritual but it was seemingly the only assimilative, traditionary bulwark against the decay of morals. Until the great mobs could be educated into a moral sense some one must cry: "Thou shalt not!" Yet any acceptance was, for the present, impossible. He wanted time and the absence of ulterior pressure (Fitzgerald 281).

Fitzgerald once reflected about Amory, "He was not even a Catholic, yet that was the only ghost of a code he had" (Turnbull 77). This remark perfectly parallels the quotation above. Amory is not a Catholic, and has not been raised as one, yet Darcy's version of Catholicism—a "ghost of a code"—is his only moral compass. Like a ghost, a past life that both is and can no longer be, and a lack of concrete substance, Amory is connected to the Church of Rome. His fickle desire to be a Catholic is based on a sentimental relationship with a rather un-Catholic Catholic Monsignor.

Amory sees value in religion, specifically in Catholicism, because it represents the opposition to a materialistic world. Before his death, Darcy believed this opposition was necessary—after all, he was a part of it! Therefore, the narrator's statements concerning Amory directly parallel Darcy's ideals.

And yet, the narrator concludes by stating that any acceptance of the Church is impossible for Amory at present. He is non-committal and will not join the camp of materialism or the camp of Catholicism. Once again, Catholicism, even Darcy's Catholicism, is nothing more than a "ghost" to him. This further characterizes Amory. Although Darcy sometimes influences him, his peers have an effect on him as well. Thus, he becomes an everyman pulled between two opposing forces that are not as different as they seem to be.

Amory's decisions and how he makes them are crucial to an understanding of his character and of the effect that Darcy has on him, particularly when Darcy is not present. Perhaps one of the most bizarre episodes that illustrates Darcy's influence on Amory is titled "The Devil" (Fitzgerald 111). The episode begins when Amory's friends decide to go out drinking and Amory decides he will not drink:

Amory considered quickly. He hadn't been drinking and decided if he took no more, it would be reasonably discreet for him to trot along in the party. In fact, it would be, perhaps, the thing to do in order to keep an eye on Sloan, who was not in a state to do his own thinking (111).

After briefly analyzing the situation, Amory makes his decision not to drink. This has less to do with responsibility and morality and more to do with pleasing himself and his peers simultaneously; he may "keep an eye on Sloan" and his friends will allow him to join their party.

After leaving the café, Amory and his friends travel to a nearby flat where Amory is offered alcohol again, but this time, he decides to drink it, suggesting his lack of resolve (112). To drink or not to drink is not a moral issue to Amory; rather, it is a decision that is based merely on convenience.

However, before he has the chance to drink, as he would like, he is faced with a very disturbing hallucination of a man chasing him:

There was a minute while temptation crept over him like a warm wind, and his imagination turned to fire, and he took the glass from Phoebe's hand. That was all; for at the second that his decision came, he looked up and saw, ten yards from him, the man who had been in the cafe (Fitzgerald 112).

Amory's hallucination of the supernatural world directly relates to his relationship with Darcy. As Brucoli asserts, "While unsuccessfully trying to point him toward Rome, Darcy intensifies Amory's sense of evil, which is dramatized by supernatural occurrences in the novel" (124). After all, is not Darcy a Catholic priest who represents a Church that asserts that there is a God and there is a devil? Amory's friends do not "see" the devil, nor do they have a friendship with Monsignor Darcy. Using words such as temptation and crept lend a sinful connotation to drinking. Similarly, warm and fire allude to hell. Amory's hallucination is a symbolic representation of what he believes is the devil. As Amory says when he relates the story to his roommate, Tom, upon his arrival at Princeton, "I've had one hell of an experience. I think I've - I've seen the devil - or something like him" (119). The fact that Amory admits this to his friend proves that it disturbs him. Furthermore, if Amory views Darcy as a personification of good, Darcy's influence reminds Amory of the existence of personified evil. This is somewhat ironic considering that Darcy himself never speaks to Amory

about the devil, nor is Darcy a particularly conservative priest who talks about right and wrong. Instead, he is said to make “religion a thing of lights and shadows” and “all lights and shadows merely aspects of God” (Fitzgerald 266). This suggests that Darcy may not even possess a concrete belief in either the devil or God, but rather, only a belief in “the idea of God” (Fitzgerald 24). Therefore, Darcy influences Amory, yet that influence is grounded not in reality, but in Amory’s perception of Darcy and of what Darcy represents. Ironically, Amory’s perception of Darcy is to Darcy as Darcy’s perception of Catholicism is to Catholicism.

## Part II

Monsignor Darcy’s impact on Amory’s character cannot be overlooked. Amory uses Darcy’s example and appears to imitate him in many situations, particularly among his friends. However, whether Amory’s imitation of Darcy is a sincere effort to copy Darcy’s philosophy or whether his actions are accidentally similar to Darcy’s beliefs is less certain. In some cases Amory becomes a secular version of Darcy. Yet, in Amory’s relationships with his peers, this is not the case.

Just as important to Amory’s maturation process are his interactions with his peers and the various love affairs he has throughout the novel. Fitzgerald uses Monsignor Darcy, Amory’s Princetonian friends, and the women he loves to shape a malleable Amory. As Charles E. Shain puts it, “What Fitzgerald is really showing is how a young American of his generation discovers what sort of figure he wants to cut, what modes of conduct, gotten out of books as well as out of a keen sense of his contemporaries, he wants to imitate” (78). Amory’s peer relationships influence his very character, which is revealed through his interactions with others. Amory is swayed by popular opinion and goes along with many schemes that are against even Darcy’s quite liberal interpretation of the Roman Catholic Church’s philosophies. This is evident in the ways he reacts to the entertainments his peers propose.

Perhaps one of the most memorable and telling scenes occurs when Amory and his friends spend a weekend at the Jersey shore. The scene opens as Alec Connage walks into Amory’s room and remarks, “Wake up, Original Sin, and scrape yourself together” (Fitzgerald 73). This phrase sums up the entire trip to the shore and its meaning for Amory. That Alec calls Amory “Original Sin” is an illustration of how Amory has been imitating his version of Darcy (Fitzgerald 73). Amory has been reminding his friends of certain religious elements, such as sin. Throughout the trip, Amory and his friends

eat at restaurants without paying for food, see movies without paying admission, and basically live at the cost of the honesty of others (76). Amory and his friends make a choice to enjoy the fruits or consequences of “Original Sin” for a weekend and take pleasure in doing what their consciences tell them they shouldn’t:

So they progressed for two happy days, up and down the shore by streetcar or machine, or by shoe-leather on the crowded sidewalk; sometimes eating with the wealthy, more frequently dining frugally at the expense of an unsuspecting restaurateur (Fitzgerald 79).

Alec’s wake-up remark to Amory is a three-fold statement with substantial consequences for the episode. Amory represents “original sin” for his peers, but not in the conventional sense of the world (Fitzgerald 79). Amory does not represent the force that makes it easy for humans to sin, or the force that makes sin fun. Rather, he is a spoilsport, a sort of conscience figure who keeps his friends from enjoying paradise, just as original sin did for Adam and Eve. (It is interesting that like the first man, Amory and Adam share their first initial.) By referring to Amory as “Original Sin,” Alec implies that Amory is a moral reminder of what college students should be doing or how they should act. Joan Allen calls the phrase “an epithet that indicates his essential seriousness and sexual fastidiousness” (76). Indeed, just as “Original Sin” keeps humans from enjoying paradise with God because it gives the human race a bend to sin, Amory keeps his friends from doing what they would like to without guilt because he sometimes reminds them, with his Darcy-esque Catholicism and philosophies, that they are doing what they ought not to do (Fitzgerald 79).

Alec’s statement also reflects what is to come during the weekend. The lower natures of the young college students will be awakened and obeyed during this pleasurable weekend at the shore. Amory knows what sin is, and yet chooses to move towards his lower nature rather than moving away from it, as he knows he should. Perhaps, in this way, Amory is not so unlike his peers. Or, perhaps, more accurately, Amory’s character is created and molded by his peers. When Alec says, “Wake up, Original Sin,” Amory agrees to follow his command (Fitzgerald 79).

This is not the only instance in which Alec Connage plays a key role in presenting Amory with a situation that ultimately shapes Amory’s character. At the end of the novel, Amory is in a hotel room with Alec, the brother of his lost love, Rosalind (Fitzgerald 247). Alec has invited a girl into

his hotel room, and is about to be discovered by detectives. Amory knows that if Alec is found with a single woman in a hotel room, the Connage family name will be scandalized (247). Because he still loves Rosalind, Amory wishes to prevent this from happening. Therefore, to save her from harm, he decides to bring the scandal upon himself. He acts as if he is the one who is with the girl, rather than Alec. This decision proves his love--or rather, as Darcy would put it, his *like*-- for Rosalind. He likes Rosalind so much that he is seemingly willing to sacrifice his reputation for her sake. Before making this decision, however, Amory reflects on the nature of sacrifice:

The first fact that flashed radiantly on his comprehension was the great impersonality of sacrifice--he perceived that what we call love and hate, reward and punishment, had no more to do with it than the date of the month (Fitzgerald 247).

The impersonality of sacrifice is a concept that is ironic considering the situation. Perhaps Amory believes that if sacrifice is impersonal, his decision to sacrifice himself for the sake of Rosalind is not really a sacrifice but rather an easier way for him to solve Alec and Rosalind's problem.

However, Amory's thoughts on this topic are not realistic. His relationship with Rosalind, his one true love, is over. He has just ended another peculiar relationship and stressful relationship with a mentally unstable woman, Eleanor. Amory then happens upon Alec in Atlantic City (243). As Brian Way puts it, "In this condition of uncertainty and confusion, believing he has lost all the ideals and illusions of his youth, Amory sets out on a pilgrimage..."(50). In such a state as Amory's, impersonal sacrifices for one's ex-fiancée seem improbable. Like Darcy who does not love his neighbor but likes him instead, Amory does not make an impersonal sacrifice, but rather a very personal sacrifice that helps himself more than Rosalind. Through his personal sacrifice for her, whom he still loves, he is able to show his love for her in a way that she cannot possibly reject because she is and will always be ignorant of his sacrifice. Therefore, his action enables him to love her once again, this time without the need for her approval.

Yet, this is not Amory's only motivation for saving Alec's reputation and ruining his own. Amory saves Alec from scandal, and acts as if he is guilty of seducing a single woman to come with him to a hotel room because he knows that if he goes through with this plan, as Stavola points

out, “the sacrifice would not be a purchase of freedom but a supercilious act for which Alec would secretly hate him” (101). He is motivated by a desire for Alec’s hatred because of his broken heart over his lost love Rosalind, Alec’s sister. Therefore, if Alec despises Amory because Alec believes that Amory made a sacrifice for him that Alec can never tell anyone about, it will avenge Amory against the Connage family in a way that only he and Alec will know. In Amory’s mind, Alec will atone for Rosalind’s mistake of leaving Amory. As is evident in this situation as well, Amory is motivated by two opposing forces: love and revenge.

This instance also involves celibacy, proving Amory’s “sexual fastidiousness” (Allen 76). Amory is not committing any act that compromises his celibacy, only his reputation among some people. In this way, he continues to carry out Darcy-esque Catholicism. However, Amory transfers onto himself Alec’s appearance of lack of celibacy, thereby appeasing the mandates of youth culture. His decision allows him to be seen favorably in Darcy’s eyes by remaining celibate and in the eyes of his peers by appearing otherwise, thus pleasing the two somewhat opposing forces that vie for his attention and his very being.

### Part III

Perhaps the most important peers who affect Amory are his love interests. As Matthew Bruccoli observes, “Each of the books of This Side of Paradise has a love story.” (125) Love is an important factor that shapes who Amory is and who he becomes. However, none of Amory’s relationships with women has an especially dramatic effect on his philosophies or beliefs. Like the other characters in Amory’s life, the women constitute only a part of the whole that influences his decisions. As stated by Kenneth Eble, “The love stories occupy less than a third of the narrative, and despite the intensity with which each is urged, they too are only passing experiences, like the others, which make their impress upon Amory’s developing self” (46). Amory’s love interests do not dramatically change or impact who he is; rather, they help to refine his character and provide him with the experiences needed for maturation. Through the ways that Amory treats the women he loves and pursues (there is a distinction), Amory’s character is repeatedly destroyed and recreated. Richard Lehan asserts that a form of self-destruction is present in all of Amory’s love interests: “Amory is in love with the image of himself in love, and his unrequited love is at best melodramatic” (63). Though Amory’s love affairs aid him in the maturation process, he has no serious plans for any of them save Rosalind Connage. Yet, even in this relationship,

his motives for loving her are questionable. Indeed, regardless of whether he is swayed at the time more by Darcy or by his peers, Amory's motives for loving are often selfish and egotistical. This is evident in the four relationships he has throughout the novel.

His first love interest is Myra St. Claire (Fitzgerald 15). He is very young when he kisses Myra, and his erratic and strange treatment of her begins a pattern of using women for his own pleasure that continues throughout the novel (15). As stated by Donaldson, "Amory Blaine manages to kiss Myra St. Claire and then, seized with revulsion, humiliates her by refusing to do it again" (116). Amory wants to love on his terms only. He is unable to accept the notion that romantic relationships with women must involve their thoughts, feelings, and emotions as well as his own. Myra is a preview of the three other women with whom Amory falls in love. She is flippant, not particularly intelligent, manipulative, and most importantly, spoiled. After Amory refuses to comply with her request to be kissed, she threatens to tell her mother that he kissed her. In reality, she is not scandalized by his kiss but rather in his refusal to repeat the supposed offence (15). Her spoiled nature and manipulative tactics are also characteristic of many of Amory's other love interests.

Kissing is an integral part of Amory's relationship with Isabelle Borgé as well. In this case, the situation with Myra St. Claire has been reversed, and Amory is the one who desires to kiss Isabelle while she refuses his advances (Fitzgerald 92). Through his firm desire to kiss Isabelle, merely for the sake of triumph over her, he proves that his relationships with women have little to do with respect and more to do with personal advancement, and perhaps retaining a macho image in front of his male peers. His choices characterize him as a man who is more interested in conquering a woman than in loving her. The narrator admits that

[t]hough he hasn't "an ounce of real affection" for her, Amory wants to kiss Isabelle, "kiss her a lot, because then he knew he could leave in the morning and not care." Not kissing her "would interfere vaguely with his idea of himself as conqueror. It wasn't dignified to come off second best, pleading, with a doughty warrior like Isabelle (Donaldson 117).

Amory wants to kiss her when he wishes for the pleasure it brings regardless of any personal feelings he has for Isabelle herself. Perhaps this desire relates to relationships with his male peers that are seen in an earlier

point in the novel. Amory is labeled in his peer group as a killjoy, an “Original Sin” (Fitzgerald 74). A successful relationship with Isabelle would allow him to prove to himself that he is not the prudish, sexually concerned man that he friends believe him to be and that in actuality he is. As Joan Allen observes, the only way Amory is able to regain his composure is “with the rationalization that he had created the wonder of Isabelle in his imagination and that by falling short of his phantasm she had spoiled his year” (76). He blames her for his inability to interact with women.

Amory’s failure to have a successful relationship with a woman is further illustrated through his relationship with Rosalind Connage. What differentiates Amory’s relationship with Rosalind from his other loves is that he does not love merely himself in her, but he loves the way that she brings him out of himself through her own ultimate selfishness (209). Rosalind does not join Amory in thinking about himself, because she only thinks of herself, and this intrigues him. His love for her is so strong that she truly changes him. As with the other love interests in the novel, Rosalind is modeled after Fitzgerald’s wife, Zelda Sayre, and another woman, Ginevra King (Lehan 65). Once again, through Rosalind, Amory is attracted to the secularism of the world, and yet he is shocked by it too: “Amory admired the flapper, although his Puritanism was shocked by her haughty freedom and exciting recklessness” (Lehan 64). The two opposing forces within Amory, the world and the Church, are never very far away.

In losing Rosalind, Amory loses an idealistic part of himself. Allen reflects:

Amory had been able to put aside his sexual squeamishness in his love for Rosalind, but the consummation of that love is prevented by still another problem [...]—the problem of money and its intimate involvement in sexual relationships (80).

Amory is unable to win Rosalind, not because he does not love her or because she does not love him, but because of his lack of money. Rather than embracing the belief of his male peers, that premarital sexuality is good, as he has been attempting to do throughout his relationships with women, he must now accept the fact that sexual relationships are inextricably linked to financial status. Thus, what Amory always believed, that “‘the worst’ in man is his sexuality,” has been proved through his relationship with Rosalind (Allen 81). This causes him to go into a depression. When she rejects him, he willingly goes into a drunken stupor that lasts until the Prohibition Act (201). Through Amory’s drinking, he tries to kill the part of him that loved Rosalind

and so to purge himself of his flawed judgment. He is successful to a point. However, the pain of memory remains so acute that he finds it difficult to forget her. This is evident in the aforementioned Atlantic City episode in which Amory sacrifices his reputation for her.

Amory's last and most bizarre relationship occurs at the end of the novel with Eleanor Savage and re-enforces Amory's idea that women are to be avoided, if possible (Fitzgerald 223-242). As with all of his other love interests, Amory loves himself in Eleanor. Eleanor proves to be too much like Amory for Amory to truly love her. As Joan Allen remarks, "...Amory sees that as he had loved himself in Eleanor there is much in both of them that is hateful" (81). Their relationship is laden with confusion and shock for Amory because of Eleanor's emphatic atheism. She pushes his doubts to extremism, and he finds this unable to bear. Amory is familiar with Darcy-esque moderate Catholicism, and moderate secularism, but not with any type of extremism of fundamentalism. Eleanor may be categorized as a radical atheist. Her effect on Amory is the opposite of what one would expect:

Leaving her after an autumn of drifting and idleness, he perceives very clearly that "this half-sensual, half-neurotic" time has not made him forget his human obligations to himself and the world. On the contrary—and this is the meaning of the chapter's title, "Young Irony"—Amory's sinking into sensuous experiences has made him realize more deeply his strong quest for religious meaning and identity (Stavola 100).

Seeing Eleanor, an extreme example of what life can be completely devoid of all faith, makes Amory question his own life.

Amory's relationships with women are motivated by a desire to please a Darcy-esque notion of morality or a peer-driven notion of secularism. Fitzgerald uses Amory to demonstrate the "sexual revolution" of the 1920s. As Brucoli states:

...Fitzgerald's sexual revolution amounted to a few pre-engagement kisses. ("Petting" in *This Side of Paradise* refers to what later generations would call "necking.") Amory is as chaste as the girls he loves. *This Side of Paradise* seemed fresh—and even sensational—because it was the first American novel of the postwar period to treat college life and the liberated women with a mixture of realism and romanticism (128).

Ironically, Amory uses his relationships with the opposite sex to walk a tightrope between the sexual experimentation of the time and chastity and purity. Of course, nowadays this seems impossible, yet nearly a century ago, Amory Blaine manages to be quite successful at it. Even though he is engaging in activities that push the limits of purity and chastity, he never loses his virginity, and thus to a large extent, he retains not only the purity that makes him an admirable character to the more conservative in the transitional generation, but also the impurity which makes him an admirable character to the liberal youth. His relationships with women simply serve as multiple examples of Amory's inability to commit to any one philosophy, perhaps because there is no one philosophy to which he can commit. Although he is faced with two alternatives, the alternatives are strangely similar.

#### Part IV

Throughout the novel, Amory is torn between two schools of thought: moderate worldly secularism and moderate liberal Catholicism. His own character is often unclear because of his apparent inability to make his own decisions. He seems to be perpetually under the influence of the morals, values and ideals of Monsignor Darcy, his Princetonian peers, or his latest love interests. Why is this so?

The answer is less obvious than it may seem. As stated by Walter Raubicheck, "Fitzgerald's protagonists are caught between the lure of the 'carnival lights' of worldly pleasure and success and the 'candles' of moral revulsion from sin" (35). Raubicheck is correct; Fitzgerald sets up the novel so that Amory is torn between two separate and seemingly distinct forces both vying for his soul. Darcy, who represents the Church, and his friends, who represent the world, are engaged in a battle for Amory--a battle in which enemy camps do not know one another, at least not personally, and all parties do not say that there is a war.

Unlike Raubicheck's statement, Darcy cannot truly be said to possess a "moral revulsion from sin" (35). Darcy is a priest who follows his own version of Catholicism. He "rather likes his neighbor" instead of loving his neighbor as the Bible and Christ mandate (Fitzgerald 24). There are no instances of Monsignor Darcy chastising or rebuking a parishioner for his sins, nor do we witness Darcy expressing displeasure with sin. Rather, we see a very accepting priest who is willing to have a close relationship with a young man who is not Catholic, has no clear intentions of becoming Catholic,

and whose decisions and actions in life are questionable even for a moderately Catholic priest. In many ways, Darcy's faith is far more shaky than one would expect a Monsignor's to be.

Amory's friends--Alec Connage, Burne Holliday, Tom D'Invilliers, Kerry Holiday, Dick Humbird, and Jesse Ferrenby-- are hardly more sinful than the average college student. They follow their lower natures and experiment with sinful endeavors, yet for their age and position in society, this may be expected. Therefore, the Princetonian friends who represent sin in the novel, in actuality, are not so different from anyone else—even from Darcy. Fitzgerald's good-versus-evil contrast seems clear, yet upon closer examination, the good and the evil characters that make up the contrast are arguably more alike than different.

The two become even more alike through Amory's interactions with Darcy and his friends. Amory's philosophies are fluid and changing. More or less, they depend on his latest interactions with his friends or Monsignor Darcy. Amory serves as a dim conscience to his peers and as a social and secular reminder for Darcy. His interactions with his peers and with Darcy represent his search for truth and, more importantly, for himself:

Underneath Amory's confused search for values and identity [...] is the constant but only dimly perceived awareness that life's moments of ecstatic transcendence [...] are what his religious tradition would also define as revelatory moments of the presence of God (Raubichek 35).

And so, Amory never truly finds himself because he is unable to completely pledge allegiance to either philosophy of extremes: religious fundamentalism or extreme secularism. In fact, Amory lacks even the conviction to make the commitment required to join his friends in their typical sinfulness or Monsignor Darcy in his Darcy-esque version of Catholicism. This is evident in his despairing cry at the end of the novel when he says, "I know myself, but that is all" (Fitzgerald 282). Although this is a somewhat exasperating statement, it suggests that Amory recognizes an aspect of himself and his character that he previously had ignored.

Thus, his cry at the end of the novel is one of confusion and despair. Without extremes, without true good and evil, Amory is a confused soul searching for truth and finding mediocrity instead. The narrator says "There was no God in his heart, he knew; his ideas were still in riot" (Fitzgerald 282). Like Darcy's, Amory's partial lack of faith is clear. In fact, Darcy

himself verbalizes it in a letter to Amory, who is in college at Princeton: “it’s that half-miraculous sixth sense by which you detect evil, it’s the half-realized fear of God in your heart” (Fitzgerald 106). Amory, like Darcy has only a half-miraculous sixth sense and a half-realized fear of God because both of them think in ideas. When one admits the idea of God, yet not the absolute existence of God, only a half-realized fear is possible. Therefore, Amory can be half-devoted to Darcy and the Church and also half-devoted to secularism and the world. Darcy identifies what Amory has always had and what allows him to maintain relationships with two different groups of people epitomized in the world and the church. Amory can maintain relations with two opposing groups because he is devoted to neither group, and neither group represents an extremist position.

Thus, “There was no God in his heart, he knew” (Fitzgerald 282). Amory knows there is no true God in his heart, but it does not follow that he does not believe in the idea of God or that he does not wish to have God in his heart. And so, as Amory lives his life and “attempts to find something to believe in,” he finds that the only thing he can truly believe in is himself (Eble 49). As stated by Joan Allen in Candles and Carnival Lights: The Catholic Sensibility of F. Scott Fitzgerald:

[he] thinks that art, politics, or religion might be the medium for the expression of the fundamental Amory, “the idle, imaginative, rebellious” essential self which is the only thing of which he is certain (73).

Regardless of whether art, politics, and religion can save Amory and give him the outlet for expression he needs, he is certain only of his own “fundamental” and “essential” self.

Amory must revolt against society because, in essence, society has revolted against him. Amory’s entire generation, indeed Fitzgerald’s “lost” generation, had no choice but to revolt because the societal institutions that had previously been unshakeable were beginning to crumble before their very eyes. There were no more distinguishable societal constructs, whether secular or religious. This is epitomized in the passage:

Here was a new generation [...] dedicated more than the last to the fear of poverty and the worship of success; grown up to find all Gods dead, all wars fought, all faiths in man shaken (Fitzgerald 282).

Edmund Wilson once wrote, “This Side of Paradise [...] is really not *about* anything: its intellectual and moral content amounts to little more than a gesture—a gesture of indefinite revolt” (81). Wilson’s argument is quite applicable to Amory’s feelings throughout the novel, particularly at the conclusion of the novel. However, as Wilson points out, the revolt was not a definite one but an indefinite one. As a character, Amory does not participate in a major revolt against either society or the Church. Rather, he experiences an inward revolt against two forces within himself. For Amory, the journey toward the dream is better than the realized dream. And so, he realizes, at the conclusion of the novel that these forces are too similar to pick sides, and instead chooses the only force he really knows: himself.

Only at Monsignor Darcy’s funeral does Amory realize what he truly wants out of life. At the funeral, Amory finally acknowledges that he wants to be what Darcy was:

He found something that he wanted, had always wanted, and would always want—not to be admired, as he had feared; not to be loved, as he had made himself believe; but to be necessary to people, to be indispensable (266).

In reality, this is what Amory has always seen in Darcy, but has never previously articulated. Amory realizes at Darcy’s funeral that to be thought indispensable to others is to be needed. For everyone at the funeral, including Amory, what Darcy represents is more important than what he is. In dying, Darcy has taught Amory another lesson, and this is that to be needed by others, no matter who those others are, can be fulfilling. Darcy is portrayed as one of the most admirable characters, not because he loved others, but he has impacted others’ lives so that they need him or at least think that they do. This is to have succeeded in life.

In writing This Side of Paradise, F. Scott Fitzgerald once remarked, “I really believed that no one else could have written so searchingly the story of the youth of our generation...” (Bradbury 43). In Amory, Fitzgerald has captured the essence of a youth that was confused and struggling to survive in a world that was quite different from yesterday’s. Amory is a sympathetic character because he is in all of us. It is a struggle to see beyond ourselves, to know others beside ourselves, to think of others before ourselves, to find our identity in the midst of a confusing world. The title of the novel, This Side of Paradise, is an ironic one. This side of paradise is far different from Adam and Eve’s Garden of Eden. For although this side of eternity can be heavenly,

in Amory's side of paradise, and indeed nearly all of America's side of paradise, the world is a confusing and uncertain place. It is not a paradise at all.

Perhaps Fitzgerald's point in writing the novel was to prove that at times, an "indefinite revolt" is all we can offer to a tumultuous and changing world (Wilson 81). Yet through writing his novel, Fitzgerald demonstrated the importance of a constant truth. Through an illustration of a world devoid of any lasting social structure and fettered with crumbling social institutions, Fitzgerald proved that social institutions are needed both to conform to and rebel against. In Monsignor Darcy, in Amory's peers and love interests, and even in Amory himself, Fitzgerald compels us to identify with one or more of his characters, and to re-evaluate our lives. Do we, like Amory, only know ourselves? Or, perhaps, like Monsignor Darcy, do we need to be needed and thus, follow our own versions of an already existing philosophy or religion? Or, maybe, we are like Rosalind, utterly incapable of sacrificing financial comfort, even for the true love of another. Regardless of who we are the most like, we see ourselves in the characters of the novel. Thus, through reading it, we come to a greater understanding of our purpose and ourselves. We realize, like Amory, that in order to attempt to experience a sort of paradise during life, we must know others as well as we know ourselves.

## Works Cited

- Allen, Joan M. "Early Success: 1917-1920." Candles and Carnival Lights: The Catholic Sensibility of F. Scott Fitzgerald. New York: New York UP, 1978. 62-83.
- Berman, Ronald. Introduction. Fitzgerald, Hemingway, and The Twenties. Tuscaloosa: U of Alabama P, 2001. 1-10.
- Bigsby, C. W. E. "Fitzgerald's Sense of Ambiguity." Readings on F. Scott Fitzgerald. Ed. Bruno Leone. San Diego: Greenhaven P, 1998. 87-95.
- Brucoli, Matthew J. "This Side of Paradise." Some Sort of Epic Grandeur. New York: Harcourt Brace Jovanovich P., 1981. 124-131.
- Eble, Kenneth. "Princeton." F. Scott Fitzgerald. Boston: Twayne P, 1963. 35-52.
- Fitzgerald, F. Scott. This Side of Paradise. New York: Charles Scribner's Sons, 1920.
- Lehan, Richard D. "This Side of Paradise." F. Scott Fitzgerald and the Craft of Fiction. Carbondale: Southern Illinois UP, 1966. 63-78.
- Parini, Jay. Introduction. This Side of Paradise. By F. Scott Fitzgerald. New York: Signet Classic, 1996. vii-xvi.
- Piper, Henry Dan. "This Side of Paradise." F. Scott Fitzgerald: A Critical Portrait. New York: Holt Rinehart and Winston, 1965. 37-64.
- Raubichek, Walter. "The Catholic Romanticism of This Side of Paradise." F. Scott Fitzgerald in the Twenty-first Century. Ed. Jackson R. Bryer, Prigozy, Ruth, & Stern, Milton R. Tuscaloosa: U of Alabama P, 2003. 54-65.
- Shain, Charles E. "This Side of Paradise." F. Scott Fitzgerald:

A Collection of Critical Essays. Ed. Arthur Mizener.  
Englewood Cliffs: Prentice Hall, 1965. 77-79.

Stavola, Thomas J. "This Side of Paradise-Amory Blaine."  
Scott Fitzgerald: Crisis in an American Identity. London:  
Vision, 1979. 73-106.

Turnbull, Andrew. Ch 6. Scott Fitzgerald. New York: Charles  
Scribner's Sons, 1962. 77-91.

Way, Brian. "Fitzgerald's Early Work-A Study in Development."  
F. Scott Fitzgerald and the Art of Social Fiction.  
New York: St. Martin's, 1980. 49-71.

**NIHILISM AND EXISTENTIALISM IN CHUCK  
PALAHNIUK'S *FIGHT CLUB***

Dan Duffy

ABSTRACT

With focus on the works of Friedrich Nietzsche, Fyodor Dostoevsky, and Chuck Palahniuk, this thesis will analyze the links between philosophy and literature and how they are used not only to explain philosophy, but also how philosophy is used as a literary device in the novels. The main works that will be focused on are Nietzsche's *The Gay Science* and *Thus Spoke Zarathustra*, Dostoevsky's *Notes From Underground*, and Palahniuk's *Fight Club*. Also included will be excerpts from works by Soren Kierkegaard and Jean-Paul Sartre.

My goal in this thesis is to portray the relevance of the nihilistic and existential philosophy in each of these works, ultimately ending with the most modern work, *Fight Club*. Little academic work has been done on this novel, and it does offer much to the philosophical as well as the literary field. This thesis will show how plot and characters are used to explain existentialism and nihilism, and for the reader to understand and connect with each work.

The reader of this thesis will find that when portraying these philosophical concepts in literature, there are specific unifying themes that tie each work together. These themes, as soon to be described in further detail, are: the role of God in existentialism, how it is possible to be a preacher of existentialism, descending and ascending journeys, and an enemy of existentialism. These roles are characteristic of each work that I have focused on. Based on research for this thesis, I will argue that they have universal value in producing an important piece of literature that reflects heavily on existentialism and nihilism.

## ACKNOWLEDGEMENTS

First and foremost I would like to thank Dr. David Tietge and Dr. Stuart Dalton for advising me during the research and writing process of this thesis. They offered me sources and ideas that I would not have been able to find or develop without their intervention. Their help throughout the research process was unmatched, and they had a big hand in helping me make this paper what it has become.

I would like to thank Dr. Brian Garvey, Dean of the Honors School for offering me the opportunity to complete such a task as an Honors Thesis. I remember him calling me up before my freshman year at Monmouth began and inviting me to join the honors program, and I am forever grateful for jumping at the chance. His encouragement and wisdom helped me to push this paper further than I ever imagined it could go.

I would also like to extend a great deal of gratitude to Michael Thomas, Assistant Dean of the School of Arts and Humanities. Since being a student of his freshman year, he has always been there to inspire me and to further my education in the English major. He has been there for literary advice, and has infused inspiration in my work where I have foreseen doubt.

### Introduction to Nihilism and Existentialism

Nihilism and existentialism are two opposing philosophical forces that can actually work with each other and help the opposing concept to make sense. The nihilist, in his most basic form, is one who believes that there is no meaning in the world, and therefore there is no need to search for it. The existentialist also believes that we are born without meaning, but this enables us to create our own meaning and create our own values. Both theories maintain that we are born into this world devoid of meaning, yet the existentialist feels that meaning can be achieved.

Chuck Palahniuk's *Fight Club* bridges the void that separates these two philosophies. The novel portrays a protagonist who has a split personality, Tyler Durden and "Joe." The Tyler that is portrayed throughout most of the novel is the unnamed narrator's alter ego. The name Joe is given to the narrator to avoid further confusion when distinguishing each side of his personality. Joe reflects the person who thinks there is no meaning in his life (that would assume he is nihilistic), and Tyler is the one who has already taken his existential journey and found meaning and purpose. Tyler is an existentialist, believing that we must hit bottom to show we are totally free in order to create meaning, which is the ultimate goal of existentialism. His disciples, who are the members of fight club, which eventually becomes Project Mayhem, are all male members of society who feel that their lives have no meaning and ultimately have no point. They view themselves as more a part of the machinery that makes up society. They have their same routines day-in and day-out, performing like clockwork so that their lives remain only neutral. They turn to Tyler Durden when he tells them that there is a way for their lives to make sense, and he offers them guidance through fight club.

The concept of the preacher in existentialism is constant throughout the researched works. This paper is going to make a deeper exploration into how each work is connected based on the philosophical ideas of nihilism and existentialism. What we find is that there are intense similarities between the character developments and the plotlines that drive each work. What differs is the way in which these preachers lead their disciples through the narrative and how existentialism is preached and nihilism is preached against.

Chuck Palahniuk can be distinguished as a disciple of existentialism, turning to philosophers such as Soren Kierkegaard and Friedrich Nietzsche as his preachers. Palahniuk acknowledges his familiarity with existential teachings in his non-fiction work *Stranger than Fiction*. In this memoir,

Palahniuk explains to the reader how Kierkegaard's existential philosophy helps to fuel the way in which he approaches the writing of his novels. He speaks of Kierkegaard to explain how he developed the premise for Joe in *Fight Club*. He explains,

On every book tour, people told me how each time they sat in the emergency exit row on an airplane, the whole flight would be a struggle not to pop open that door. The air sucking out of the airplane, the oxygen masks falling, the screaming chaos and "Mayday! Mayday!" emergency landing, it was all so clear. That door begging to be opened (213).

Palahniuk incorporates this thought into *Fight Club* as the narrator goes through the same struggles. He knows what is possible and is under his control. All he has to do is pull that lever on the emergency exit, and he is the catalyst that enables complete chaos to take over. Palahniuk explains this by further referencing Kierkegaard.

(Kierkegaard) defines dread as the knowledge of what you must do to prove you're free, even if it will destroy you. His example is Adam in the Garden of Eden, happy and content until God shows him the Tree of Knowledge and says, "Don't eat this." Now Adam is no longer free. There is one rule he can break, he *must* break, to prove his freedom, even if it destroys him. Kierkegaard says that moment we are forbidden to do something, we will do it. It is inevitable [...] According to Kierkegaard, the person who allows the law to control his life, who says the possible isn't possible because it is illegal, is leading an inauthentic life (213).

This is the basic premise for what became *Fight Club*. The novel revolves around a group of young men doing everything they're not supposed to do in order to express that they are free from the laws of society. It is not so much rebellion as it is displaying the freedom that they are aware of possessing. To explain the actions of fight club and Project Mayhem, Palahniuk says, "you can make what Kierkegaard called your 'Leap of Faith', where you stop living as a reaction to circumstances and start living as a force for what you say you should be" (215). This existential thought applies to each work addressed.

Although he comes later in the evolution of existential philosophy, Jean-Paul Sartre devised the most direct distinctions as to what is involved in existential thought. His paper titled "Existentialism is a Humanism"

addresses the definition of existentialism as simply and as directly as possible. Sartre breaks existentialism down into one simple phrase: “existence comes before essence” (Sartre 1). This phrase means that we are not born with an intended meaning or destiny. Rather, we are born with no direction and no innate morality. We are born with nothing at our births except for our bodies, so we are free to search for our own meaning, and any destiny that we believe we must achieve is always created by the self, and not by a preconceived power.

Sartre makes five main points to back up his notion of “existence comes before essence.” The five main points he makes, as summarized by translator Bernard Frechtman are

1. We are totally free. That is, we are not determined by heredity or environment.
2. Since there is no God to define our being, we must define our essence.
3. We are completely responsible for our actions, and we are responsible for prescribing a moral philosophy for everyone else too. We create our morality.
4. Because of the death of God and the human predicament, which leaves us totally free to create our values, we must exist in anguish, forlornness, and despair.
5. Yet we should celebrate the fact that we are creators of our essence and our values. (1)

The second point in that list can not go without the acknowledgement of one of this paper’s main focuses, Friedrich Nietzsche. The nihilistic/existential phrase “God is dead” was made famous in his work *The Gay Science*, and it is perhaps the phrase for which Nietzsche is most famous. However, it is also perhaps his most misunderstood phrase, and it is one that had typecast him into the philosophy of nihilism rather than existentialism. Nihilism was in fact Nietzsche’s enemy, and by laying the groundwork for nihilism in order to preach against it, he made himself sound as though he was himself a nihilist. However, this was not the case. Nietzsche, as discussed later, used existentialism as his voice of reason against nihilism.

Palahniuk derived from Nietzsche the thought that God does exist, yet he has turned our backs on us. By having Tyler Durden make this statement, it keeps God in the picture, yet enables us to abandon the idea that He would care to give us essence before our existence.

Fyodor Dostoevsky, in *Notes from Underground*, leaves God completely out of the novel, which suggests that God is irrelevant to his interpretation of existentialism. Without the mention of God, the implication is that we *must* be free to create our own values. The role of God in existentialism and nihilism brings us to our first major chapter.

### **The Role of God in Existentialism and Nihilism**

In his paper titled “Variations on the ‘Death of God’ Theme in Recent Theology,” F. Thomas Trotter states,

The variations on the theme of the “death of God”—absence, disappearance, silence, withdrawal, eclipse—indicate the particular character of the theological problem but also reveal the difficulty in defining exactly what the Nietzschean expression means in contemporary theological vocabulary (42).

From this, the question becomes: What exactly was it that sparked this notion of God being dead, and what was Nietzsche stressing when he made that famous statement? Was he providing us with an atheistic and completely nihilistic notion that there has never been a higher creator and that we are living our lives in a void? This is the fundamental question that has plagued existential thought since its conception.

Post-Nietzschean philosophers pondered this question and have tried to make sense of Nietzsche’s statement, defending his conception that it is really the *symbol* of God that is dead. Existential and Christian philosopher Martin Buber’s defense for Nietzsche was that the statement “God is dead” translates into “only that man has become incapable of apprehending a reality absolutely independent of himself and having a relationship with it” (qtd. in Trotter 44). After being raised in a world where God has played such a vivid role in our lives, to lose this idea would devastate humanity. We have become comfortable in our own skin by thinking that there is a higher force that is controlling our lives. According to Buber, for man to discover that he is completely free would devastate him, and would ultimately lead to chaos.

Sartre makes similar suggestions, saying “God ‘spoke to us and now is silent, all that we touch now is his corpse’” (qtd. in Trotter 44). Trotter furthers Sartre’s statement by pointing out

It may be distressing that God does not exist, because all possibility of finding values in a heaven of ideas disappears along with God [...] No longer are there metaphysical or theological supports for moral action. Man is thrust into his selfhood and loneliness to act responsibly--to be, in short, a man (44).

To view God as dead is to view oneself as being fully alive, responsible, and capable of one's own actions. Divine intervention cannot exist, and man is free.

In each work researched, the role of God plays an extremely important part not only in the plotline of each work, but in the fundamental ideas that have spawned existentialism and nihilism. God signifies a higher power than mankind. He represents a creator of this world and of all things associated with it, and is seen as providing for us an ultimate destiny that we can achieve. The concept of God implies that we are born with certain innate laws, and whatever we become has been prejudged. Sartre clarifies this by saying God is "the transcendent ground of all meaning, the predetermined source of all value" (qtd. in Dalton).

The absence of God in these works is not meant as an attack on any religion; it only shows us that it is possible we can create our own meaning. The absence of God in the works of Palahniuk, Dostoevsky, and Nietzsche is what makes their philosophical content even possible. In order to reach existential enlightenment, the first thing that must be done is to abandon the idea that a higher power gave us moral judgment and innate values upon our birth. In existential literature, the way for the reader to understand this is to abandon the thought of God completely. So "if God didn't exist, everything would be possible: If there were no objective foundation for our value judgments, then people would have to confront the fact that they are free to create values however they want" (qtd. in Dalton). This is the concept that Palahniuk, Nietzsche, and Dostoevsky use to create their protagonists.

But herein lies the paradox of existential thought: in our search to find our meaning, we could also very well destroy ourselves without recovery before we find it. The aforementioned authors create protagonists that are born out of this thought that there is no God that we must answer to, and they go about living a lawless life to prove their freedom. If this were to translate into every human being on Earth, it would create complete chaos. According to Janko Lavrin in his article on Nietzsche and Dostoevsky, "Our moral values, which have been based on God's existence, become obsolete, and the anarchic formula that 'all things are lawful' may eventually lead to universal

anarchy, chaos, and destruction” (162). So the majority of the world *does* need this notion of God so that complete worldwide anarchy does not ensue. What these authors have done is show us what a world with no God looks like and how human beings would react to such a world.

For Nietzsche, God is discussed in perhaps one of his most famous lines. In *The Gay Science*, his character The Madman runs into a village, shouting, “Whither is God...I shall tell you. *We have killed him*--you and I. All of us are his murderers...God is dead. God remains dead. And we have killed him” (Kaufmann 95). This is his most misunderstood line in all of his works; he has been viewed as nothing more than a radical atheist due to this statement. What many people may not realize is that previous to writing his philosophical works, Nietzsche had studied to become a pastor at Bonn University, and was therefore seeking some sort of religious path in his life (Lavrin 163). Nietzsche had been a devout Christian growing up, but all he had seen around him was an abandonment of God. Through this abandonment, he came up with his philosophy of God being dead. Upon a closer look at his statement, one can see that he is not saying that God never existed. Rather, he is saying that God was once alive and well and went so far as to create man. However, the lack of human spirituality has killed God. Nietzsche believes we have turned our backs on our creator, and because of this, God is dead. With God being dead, we remain free to create our own meaning.

Fyodor Dostoevsky uses God in a different manner in *Notes from Underground*. What Dostoevsky does is keep God out of his novel altogether. The absence of God is more powerful than one can initially realize. By leaving God out of an existential work, Dostoevsky gives the implication that God is of no importance to the philosophy. Where Nietzsche says that God is dead, and from there we must find meaning within ourselves rather than through a spiritual being, Dostoevsky disregards the notion of spirituality. He even references Darwin’s theory of evolution:

Once it is proved to you, for example, that you descended from an ape, there’s no use making a wry face, just take it for what it is. Once it’s proved to you that, essentially speaking, one little drop of your own fat should be dearer to you than a hundred thousand of your fellow men, and that in this result all so-called virtues and obligations and other ravings and prejudices will finally be resolved, go ahead and accept it, there’s nothing to be done, because two times two is-mathematics. Try objecting to that (13).

Not only does Dostoevsky use the ideas of evolution, that is man descending from apes, but he goes on to seek truth through mathematics, leaving truth from a spiritual world out of the picture.

In *Fight Club*, Palahniuk has the disciples of fight club sometimes speak for their preacher Tyler, and it is a mechanic that has been a part of fight club who speaks some of the most prominent “Tyler Durden dogma” (141). The mechanic explains to Joe

What you have to understand, is your father was your model for God [...] If you're male and you're Christian and living in America, your father is your model for God. And if you never know your father, if your father bails out or dies or is never at home, what do you believe about God? [...] What you have to consider is the possibility that God doesn't like you. Could be, God hates us. This is not the worst thing that can happen (140-141).

What Tyler preaches about God to his members of fight club is directly linked to previous thoughts of philosophers before him. He keeps the thought of God in the existential formula, but he is saying he was never there to help us. He was more like a father who abandoned us. He was there to help create us, but he gave us no lesson for life and nothing to live by. Instead, we are left to decide that for ourselves. Even if God does exist, He is irrelevant, as He would never intervene in our lives.

Fight Club acts as a replacement for any notion of religion for the men involved. Joe substitutes the environment of fighting for an environment of religious acts. “HELLO!” he says, “I am so ZEN! This is BLOOD. This is NOTHING. Hello. Everything is nothing, and it's so cool to be ENLIGHTENED. Like me” (64). Joe is on his way to finding meaning without actually finding any meaning. In living a life with no God figure to look after, he is free to do anything, for nothing has any true consequence. Joe describes fight club as having “hysterical shouting in tongues like at church, and when you wake up Sunday afternoon you feel saved” (51). “Fight club becomes the new religion without religion” (Mathews 92).

Fight club offers a consequence-free way for men to bond with each other. Now, the reader may feel that there are obvious consequences to their behavior: broken noses, eye sockets pounded in like meat, spitting teeth into your bathroom sink at night, death. But to these existential disciples that Tyler Durden has groomed, there is no such thing as consequence. The broken noses and disfiguring injuries these men receive mean nothing

because there is no need for them to be in perfect form anyway. And as for death from some action of fight club or Project Mayhem, it is not just another part of life, but it can also be seen as the existentialist's most free moment.

### **The Ascending Journey: From Destruction Comes Creation**

In each novel, the protagonist and disciples go on a journey of descension followed by ascension. The descending journey is usually literal, but metaphorically it is a journey of destruction. The ascension that follows is a response to that initial journey, and metaphorically it is a re-creation that eventually leads the existentialist to enlightenment.

*Thus Spoke Zarathustra* begins with Zarathustra on top of a mountain, on the verge of taking a journey toward the bottom to preach existentialism to anyone who will listen.

I shall join the creators, the harvesters, the celebrants: I shall show them the rainbow and all the steps to the overman. To the hermits I shall sing my song, to the lonesome and the twosome; and whoever still has ears for the unheard of—his heart shall become heavy with my happiness. To my goal I will go—on my own way; over those who hesitate and lag behind I shall leap. Thus let my going be their going under (Kaufmann 136) .

Zarathustra acknowledges that while on his descending journey, he seeks only companionship and will not tolerate anyone who is hesitant to listen to his words. If someone hesitates, he feels they are not ready to accept an absence of God and therefore are not ready to look to achieve the *Übermensch*, which translates to the overman. The overman is a superior person who can create their own values once they reject the values that had been previously placed upon them.

Zarathustra then acknowledges the ascending journey the disciples must take in order to be with him and have their chance at existential enlightenment. In the fourth part of his journey, Zarathustra waits at the top of the mountain and says,

Thus men may now come up to me; for I am still waiting for the sign that the time has come for my descent; I still do not myself go under, as I must do, under the eyes of men. That is why I wait here, cunning and mocking on high mountains, neither impatient

nor patient, rather as one who has forgotten patience too, because his “passion” is over (351).

Although Zarathustra has already taken his initial descending journey to collect disciples, he contemplates a return trip to further persuade potential disciples to follow him up the mountain. But he realizes that, as he said before, he cannot preach to hesitant men. If a man needs additional persuading to get him to the top of the mountain, he is not worthy of Zarathustra’s preaching. Thus, Zarathustra must continue to wait at the top for disciples to join him.

*Fight Club* begins where the story ends, at the top of the fictitious Parker-Morris building, the tallest building in the world. Project Mayhem occupies the top floors and the members are blasting the windows out and throwing file cabinets onto the streets below. At the top of the building is Tyler Durden. He is putting a gun in Joe’s mouth as he counts down the minutes before explosive charges are set to go off and topple the building. Tyler and the members of Project Mayhem are about to achieve their supreme moment of existentialism. They will destroy not just the physical place where they stand, but they will destroy themselves completely in order to become free.

The second chapter takes us to where Joe’s story actually begins, in the basement of a church. He is attending a support group for men with testicular cancer called “Remaining Men Together.” He encounters Bob, a former bodybuilder who represents the height of masculinity with his once-muscular physique, wife, and two children. Not only was Bob physically masculine with his sculpted body, but he also took on the manly duties of being financially stable enough to support a family, and his testicles were in proper working order to produce children naturally. However, once Bob got cancer, his testicles were removed, his wife divorced him and took the children, he went bankrupt, and just to take away from his masculinity even more, the hormone treatment for the cancer gave him “bitch-tits” (17). Bob was a man who was riding the height of life, and then everything that he had was destroyed, and now he is in this church basement with Joe. Physically and metaphorically, Bob is a representation of the descending journey of existentialism.

When Bob holds Joe in his big arms to cry, Joe is able to let go. Being around so much despair allows Joe to be released from his touch with the outside world that has control over him. At these meetings, he would not have to think about his condo, his job, or his next business trip. While he attends these meetings, he is able to lose all hope, and “losing all hope was

freedom” (22). If Joe is to seek hope, then he is saying that there is some sort of goal that must be achieved. If he doesn’t properly execute the steps to this goal, then he may fail and thus suffer consequences. So if he is to let go of hope, then he won’t have to suffer any consequences and therefore be free. Joe feels that he is free by subjecting himself to the tragedy that brings these support groups together. He continues to attend more groups, presiding at church basement meetings for not only testicular cancer, but for ascending bowel cancers, brain parasites, and even sickle-cell anemia (Joe is Caucasian). Every night that he attends a support group, he feels free again from his normal daily routine. Through these meetings, he is able to “hit-bottom,” which becomes a major theme in Tyler Durden’s preaching.

His descending journey comes to a halt, however, when he encounters another “faker” in the support groups, Marla Singer. Marla is sort of an existential counter-part to the Joe/Tyler protagonist, because “(she has) no real sense of life because she has nothing to contrast it with” (38). Her reason for coming to the support groups is the same as Joe’s, so that she can feel so alive when the feeling of impending death consumes the rest of her. “What you have to know is that Marla is still alive. Marla’s philosophy of life [...] is that she can die at any moment. The tragedy of her life is that she doesn’t” (108). She knows she isn’t sick, and therefore she feels more alive. But the other “faker” in the support groups ruins Joe’s view of the people around him. “Because I can’t hit bottom, I can’t be saved” Joe says in regard to Marla’s presence (22). It is after Marla intrudes on his life that he knows he must leave the support groups in search of another way to hit rock-bottom, and this is how we are introduced to Joe’s alter ego of Tyler Durden and to fight club.

The important aspect about fight club in terms of the descending and ascending journey is that it starts in the basement of a bar. Fight club brings groups of men together in the basement to destroy themselves to a point close enough to death that they can feel alive when the fight is over. The idea of fighting to feel alive stems from the first fight between Joe and Tyler (keep in mind the first fight is really Joe/Tyler beating himself up). “Instead of Tyler” Joe says, “I felt I could finally get my hands on everything in the world that didn’t work” (53). Joe knows that he is unhappy with the world in which he lives, and he wants to break free and be liberated from his corporate lifestyle. After Joe and Tyler’s first punches connected, Joe says, “We were still alive and wanted to see how far we could take this thing and still be alive” (53). Joe/Tyler had found a new way to come close to death without having to attend the support groups and be a “faker”. Fight club is more real because it

cannot be faked like a support group for testicular cancer. You really had to give and take punches, and you really had to destroy yourself and something else in order to recreate something better.

After their first fight, Joe asks Tyler what it was that he had been fighting. By asking this, Palahniuk allows fight club to break away from a purely physical primal fighting with no purpose. There is always some hidden conflict that each member of fight club is really fighting. The member does not want to destroy the other member of fight club; rather he wants to destroy what he is fighting in his mind. Tyler tells Joe he was fighting his father during their first fight. This idea of the father takes us back to the Role of God in this existential literature. By saying he was fighting his *father* he also means that he is fighting the thought of God, which is the first existential step. This takes us back to the mechanic preaching to Joe and linking our physical father with God.

Before Joe and Tyler had their first fight, (remember, it is still really just Joe/Tyler beating up on himself) Joe says, "At the time, my life just seemed too complete, and maybe we have to break everything to make something better out of ourselves" (52). Again, he understands that the first step to enlightenment is to take that descending journey and destroy the world he knows so that he can re-make it how he wants and how he believes it should be.

Eventually, destroying things through fight club has to be taken to the next level, which is where the ascending journey for all these men truly begins. In a horrific scene in the novel, Joe fights the member known as Angelface, who, as his name suggests, has the most perfectly structured face of all the men in fight club. It's his first night, and Joe taps him for a fight. Joe knocks him down and proceeds to pound his eyes and cheekbones in like meat, and any teeth that are left in Angelface's mouth are sticking through his lips. Tyler says to Joe that he had never seen him destroy something so completely, and Joe tells him that he "wanted to destroy everything beautiful (he'd) never have [...] (He) wanted the whole world to hit bottom" (123). Tyler realized that he would now have to either shut down fight club or take it to the next level.

Almost immediately after the fight against Angelface, Project Mayhem is formed. Project Mayhem brings fight club out of the basement and "(teaches) each man in the project that he had the power to control history. We, each of us, can take control of the world" (122). What Tyler wants from Project Mayhem is to bring society to its knees and reset civilization. Tyler's view on the goal of Project Mayhem is as follows.

Like fight club does with clerks and box boys, Project Mayhem will break up civilization so we can make something better out of the world. “Imagine,” Tyler said, “stalking elk past department store windows and stinking racks of beautiful rotting dresses and tuxedos on hangers; you’ll wear leather clothes that will last you the rest of your life, and you’ll climb the wrist-thick kudzu vines that wrap the Sears Tower. Jack and the beanstalk, you’ll climb up through the dripping forest canopy and the air will be so clean you’ll see tiny figures pounding corn and laying strips of venison to dry in the empty car pool lane of an abandoned superhighway stretching eight-lanes-wide and August-hot for a thousand miles (125).

The imagery that he creates shows us the results of the modern industrial world: highways, skyscrapers, department stores--all abandoned because society realizes that by destroying all of this we can go on to create something better for ourselves.

Project Mayhem’s ascending journey eventually takes them to the top of the fictional Parker-Morris building, which is where the novel began. We return to the scene with Tyler putting a gun into Joe’s mouth and counting down the minutes until explosives are set off and the building collapses with all the members inside. However, by this point we understand that Tyler is just a split side of Joe’s personality, so it is really Joe/Tyler pointing a gun into his own mouth. It is here that the most existential moment in the novel takes place. The ascending journey has been completed, since Joe/Tyler is on the very top of the building, and now the only decision is whether or not to pull that trigger to decide truly his own destiny that he created for himself. According to French philosopher Albert Camus, Joe/Tyler has to make the most important existential decision. Camus believes, “There is but one truly philosophical problem, and that is suicide. Judging whether life is or is not worth living amounts to answering the fundamental question of philosophy” (qtd. in Casado de Rocha 112). By being able to choose whether to live or die, we show that we are completely free. And by Joe/Tyler deciding that he has the power to overcome himself and pull the trigger on his own, he is showing that he is truly the most existential and free person in all of Project Mayhem. He took the journey that involved the most descension and ascension, and now he is showing that he can choose to be free from all the grips that the world holds on him. He started his own destiny by forming fight club, and now he is completing that destiny by turning a gun on himself.

This thought of suicide being an existential crisis also stems from the teachings of Zarathustra. Part of Zarathustra's preaching concerns "Voluntary Death," and he says, "I commend to you my sort of death, voluntary death that comes to me because *I* wish it" (Kaufmann 97). Zarathustra believes that man can die at a "right time," and this is precisely the moment where Tyler knows he has completed his journey and can now set himself free. Zarathustra's teaching says, "Free of death and free in death, one who solemnly says No when there is no longer time for Yes: thus he understands life and death" (99).

In *Notes from Underground*, the Underground man goes on a similar journey, but the story ends at a different point in the journey than does *Fight Club or Thus Spoke Zarathustra*. The narrative of the Underground Man is told in the opposite direction, but it still holds true to the metaphorical journey that Joe/Tyler and Zarathustra take.

The novel begins with the Underground man being underground, but the actual storyline of his life begins in "Apropos of the Wet Snow" when he is much younger. The first part titled "Underground" occurs when he is forty years old and has descended from his old life of seeking a social prominence, and is now in a sort of limbo contemplating his search for meaning. He hints at his nihilistic thinking that has sent him underground, saying of himself,

I have never managed to become anything: neither wicked nor good, neither a scoundrel nor as honest man, neither a hero nor an insect. And now I am living out my life in my corner, taunting myself with the spiteful and utterly futile consolation that it is even impossible for an intelligent man seriously to become anything, and only fools become something (5).

At first glance this novel appears that it appears to be a work of strict nihilism, but this is the point of the journey. When fight club is in the basement, there seems as though there is no point to anything that is going on until their ascension. The same goes for Zarathustra, where, as he descends, there seems to be no meaning in the journey because he must still return to await his possible disciples. When his disciples finally follow him up the mountain then they gain meaning, and Zarathustra's journey gains further meaning as well.

While underground, the Underground Man acknowledges the existential concept of creation through destruction.

Man loves creating and the making of roads, that is indisputable. But why does he so passionately love destruction and chaos as well? [...] Can it be [...] because he is instinctively afraid of achieving the goal and completing the edifice he is creating?(33).

This process is exactly what the Underground Man finds himself in the middle of right now. Right away when he begins his narrative, we sense the tone of personal destruction. He is only 40 years old, but he tells us “I am a sick man [...] I am a wicked man. An unattractive man” (3). There is nothing uplifting he can tell us about himself. As Tyler Durden would say, the Underground Man has found his “rock-bottom.”

In “Apropos of the Wet Snow,” the Underground Man begins the story of what took him underground. He is twenty-four years old, but already acknowledges, “[...] my life was already gloomy, disorderly, and solitary to the point of savagery. I did not associate with anyone, even avoided speaking, and shrank more and more into my corner” (42). Since he is not yet underground, this is further proof that since he was a younger man he has been on a continuing journey to hit rock-bottom.

By the end of the novel, after all of his preaching (which will be discussed in further detail later on), the Underground Man hints at the coming of an ascending journey. His recollection of his life prompts him to end his story of being underground and move on.

As far as I myself am concerned, I have merely carried to an extreme in my life what you have not dared to carry even halfway, and, what’s more, you’ve taken your cowardice for good sense, and found comfort in thus deceiving yourselves. So that I, perhaps, come out even more “living” than you (129-30).

He then ends his narrative by telling us, “I don’t want to write any more ‘from Underground’...” (130). This statement hints toward his ascension to discover meaning. If he is finished with his life underground, the next step he must take on his existential journey is to begin his ascension. This is where the end of the novel teeters between existentialism and nihilism. If the Underground Man remains where he is, it is a nihilistic journey that keeps him at “rock-bottom.” If he begins his ascension towards enlightenment, then he can pull himself from “rock-bottom,” and the existential journey continues. The novel ends with him still toying with the idea that there is a reason for him to retreat from his self-condemnation underground; because of this, the novel ends in existential ambiguity.

### The Preacher of Existentialism

Each work discussed involves a preacher: a protagonist to tell a group of people how to reject God along with the social assumptions of behavior to become free. This concept of the preacher holds a strong presence throughout each work. In the literary form, each author has used this method to tell his side of existential and nihilistic philosophy.

Nietzsche uses preachers in both *The Gay Science* and *Thus Spoke Zarathustra* to preach two versions of the same concept. Nietzsche's most famous existential comment appeared first in Aphorism 125 of *The Gay Science*. In this aphorism, The Madman runs into a village filled predominately with atheists. "I seek God! I seek God!" he shouts, and then begins to ask where it is that God could have gone (Kaufmann 95). He then tells the atheists that God was indeed once alive, but due to their abandonment, he is now dead.

Whither is God! I shall tell you. We have killed him- you and I. All of us are his murderers. But how have we done this? [...] Who gave us the sponge to wipe away the entire horizon? [...] What did we do when we unchained the earth from its sun? Whither are we moving now? [...] God is dead. God remains dead. And we have killed him (95).

The Madman blames mankind for the death of God, and preaches that by killing God mankind is forced to create his own essence. Since we ourselves have killed God, then we have made ourselves responsible for discovering our own meaning in our lives. As The Madman says, we have unchained the earth from the sun, and we are now free from any outside forces to influence our behavior.

In *Thus Spoke Zarathustra*, Nietzsche furthers his protagonist's preaching about creating our own meaning through the preacher Zarathustra. Zarathustra's primary preaching is "God is dead" and that the "overman" must be taught (Kaufmann 124). He believes that "man is something that shall be overcome," that "man is a rope, tied between beast and overman--a rope over an abyss" (124-126). Man is stuck in the middle between his primitive animalistic instincts--such as hunting and gathering--while the overman lies on the opposite, and more cerebral, end of the spectrum. To Zarathustra, the overman is one who can understand that God is dead and that we are free to design our own values in our lives. Man is just an animal that is obligated to obey laws that are handed down by God or society, and he

simply exists with no essence. The overman, on the other hand, is one who has overcome man and can create his own laws for himself.

Zarathustra's preaching of God being dead is especially interesting in the chapter titled "Retired" in which Zarathustra encounters a pope. Zarathustra tells the pope that "the old god in whom all the world once believed no longer lives," and the pope responds, "As you say, [...] And I served that old god until his last hour. But now I am retired, without a master, and yet not free, nor ever cheerful except in my memories" (371). The pope seeks out Zarathustra so that he may preach about how to be happy and free in the absence of God.

Zarathustra first explains why God is dead, saying that He died out of pity for mankind. "You know how he died? [...] That he saw how *man* hung on the cross and that he could not bear it, that love for man became his hell, and in the end his death?" (372). Zarathustra argues that God was forced to pity His creation known as mankind, and His heart had been broken since we had taken Him for granted, and could not endure anything that He intended for us to endure. "Let him go. Let him go, he is gone," Zarathustra tells the pope (372). He is telling the pope that there is no hope for a return of God, and thus he has no choice but to look to himself and achieve the overman. The external rules set by God are gone, and the pope must now accept that he is free to act as he chooses.

Zarathustra also says that God should have been denied before He had even died, because, "Whoever praises him as a god of love does not have a high enough opinion of love itself. Did this god not want to be a judge too? But the lover loves beyond reward and retribution" (373). This is another reason why Zarathustra believes that we should achieve the overman. If we achieve the overman and create values for ourselves, then there can be no judgement. If we believe that how we act is right and in our best interest, then we are free from judgment. To live with a fear of contempt from God is not living at all. Through having the pope look toward Zarathustra for advice, the preacher of God becomes the disciple to the preacher of existentialism, and further solidifies the existential and nihilistic concept of God being dead.

*Fight Club's* preacher is of course Tyler Durden. Tyler Durden's disciples come in the form of all the members of Project Mayhem (formerly fight club), including Joe. All of his preaching revolves around his statement "It's only after you've lost everything that you're free to do anything" (70). Tyler teaches his disciples that destruction is the key to freedom. We must

constantly sacrifice so that we can attempt to rebuild ourselves and our surrounding environment.

This concept is best exemplified while Joe is talking over the phone to a police detective. The detective is inquiring about the recent explosion that occurred in Joe's condo and sent all of his possessions crashing in flames onto the street below. As Joe talks with the detective, Tyler whispers into his ear

Disaster is a natural part of my evolution towards tragedy and dissolution [...] I'm breaking my attachment to physical power and possessions because only through destroying myself can I discover the greater power of my spirit [...] The liberator who destroys my property is fighting to save my spirit. The teacher who clears all possessions from my path will set me free (110).

These statements allude to a couple of things. First, Tyler is reiterating the previous concept of creation through destruction. Joe can start his life over since his apartment and all his possessions are blown up. Also, by using the third person and saying "the teacher," Tyler acknowledges that he is a preacher and is able to help people just like Joe realize what they are truly capable of in life.

In perhaps the most existential preaching in all of the works I have studied, Joe/Tyler points a gun at someone's head to make him listen to his existential thoughts. Tyler makes Joe take an unloaded handgun and meet a late-night convenience store clerk named Raymond K. Hessel outside the store after his shift. Joe approaches Raymond and points the handgun in his face, demanding his wallet. He tells Raymond he's not after his money, because "not everything is about money" (152). This is about pulling a nihilistic person out from hitting rock bottom and forcing him to infuse his own meaning into his life. This is about helping someone hit rock-bottom and then showing them that the only place they can go from there is up. On Raymond's driver's license, Joe notes that he lives in a basement apartment. When we look at the existential journey, the fact that he currently resides in a basement is further evidence that Raymond has hit his "rock-bottom." Raymond's only existential problem is that he is completely neutral, living a nihilistic lifestyle and pursuing nothing more than a minimum-wage job to fund his basement apartment.

Joe assures Raymond that tonight he is going to die. He tells him that his parents are going to "have to call old doctor whoever and get your dental records because there wouldn't be much left of your face" (153). He

then pulls out an expired community college ID card from Raymond's wallet and asks what it is that he studied. He tells him he was studying biology and wanted to become a veterinarian, but it was too much work. Joe tells him, "You could be in school working your ass off, Raymond Hessel, or you could be dead" (154). Joe pushes the gun harder against Raymond's cheek and tells him,

I'm keeping your license, and I'm going to check on you [...] if you aren't on your way to being a veterinarian, you will be dead. [...] I'd rather kill you than see you working a shit job for just enough money to buy cheese and watch television (154-5).

Joe starts Raymond's life over for him. He makes sure that Raymond hits bottom so that he will begin his ascending existential journey and create something out of a nihilistic, neutral life. By instilling the fear of having a gun pressed into his face and bringing him so close to death, Joe assures that "Raymond's dinner is going to taste better than any meal (he) has ever eaten, and tomorrow will be the most beautiful day of (his) entire life" (155).

In order to show the members of Project Mayhem the power they have to go against society, Tyler sets up general guidelines that will enable them to eventually be free of even his rules. Now, the reader may think that by establishing laws within Project Mayhem, it disables them from ever being free. However, Tyler's rules simply provide a way for the members to escape the rules that have been set up by the world in which they live. By establishing the first two rules, which are both "You do not ask questions," then the members must trust in Tyler. So when Tyler tells them to put bumper stickers that say "Drunk Drivers Against Mothers" or "Recycle the Animals" onto random cars, they do not question it because they know what they are doing is going against a general norm of society while staying inside Tyler's parameters.

In *Notes from Underground*, the Underground Man is generally preaching to the audience who is reading his "notes." He does, however, find one very important disciple: a young girl named Liza. After opening the conversation, he tells her about how he witnessed a coffin being carried out of a basement earlier that day. Right away, the Underground Man alludes to the existential journey, whereby in death one can become free; and to the physical descending and then ascending journey. The discussion leads into death, and Liza asks why she should someday die. The Underground Man

immediately tells her of the descending journey and compares her to the girl that was in the coffin that morning.

You're young now, good looking, fresh [...] But after a year of this life you won't be the same, you'll fade. [...] You'll go from here to somewhere lower, another house. A year later--to a third house, always lower and lower, and in about seven years you'll reach the Haymarket and the basement. That's still not so bad. Worse luck will be if on top of that some sickness comes along, say some weakness of the chest [...] or you catch cold, or something. Sickness doesn't go away easily in such a life. Once it gets into you, it may not get out. And so you'll die (91).

The way in which the Underground Man sees Liza's future is ironic because of where his future takes him. As mentioned before, his narrative begins sixteen years after his encounter with Liza, and he has condemned himself to live Underground and is himself a "sick man."

We learn more about the Underground Man's life while he is preaching to Liza. The way in which he was raised helps us understand why he would have so many nihilistic thoughts.

You see, Liza--I'll speak about myself! If I'd had a family in my childhood, I wouldn't be the same as I am now. I often think about it. No matter how bad things are in a family, still it's your father and mother, not enemies, not strangers. At least once a year they'll show love for you. Still you know you belong there. I grew up without a family: that must be why I turned out this way [...] unfeeling (94).

This coincides with Tyler Durden's view of the linking of our physical father with God. By having no father-figure to look to, the Underground Man had no God-figure to look to, and therefore had no choice but to create his own values. While this might have made him a bitter man with a bleak outlook for everything (even more of a nihilist), he does have a sense of a deeper meaning to life. So while he preaches to Liza that life happens and then we dwindle and die away, he does understand there may still be a reason to live the life we have.

### Enemy of Existentialism

After overcoming the thought of God, each novel involves overcoming another outside influence on the path to existential enlightenment. This concept of an enemy is something I developed while trying to find out what each of these authors were telling us to free ourselves from after we abandoned the thought of God. After the existentialist abandons God, there is one more outside influence that he must overcome; some additional externality that may get in the way of letting him create his own values and establishing his own morality.

In *Thus Spoke Zarathustra*, Zarathustra's existential enemy is Man himself and man's Ego. Zarathustra feels that after overcoming God, Man must reject his conscious mind, because a conscious mind is one that is capable of still holding on to laws of society. "My ego is something that shall be overcome: my ego is to me the great contempt of man..." Zarathustra says in his preaching "On the Pale Criminal" (149-50). This is why Zarathustra preaches the overman, because Man himself is unable to cope with the idea of true existential freedom, but the overman is the one who can let go of the Ego and abandon all previous virtues that were infused into his life.

Zarathustra believes that "(man is) a heap of diseases, which, through his spirit, reach out into the world: there they want to catch their prey" (151). When Zarathustra says that man is diseased, he means that he is diseased with values that were set in place before man could judge if these values were right for him. If man can overcome his diseased Ego and cleanse himself of the values that were instilled in him, he can achieve the overman. To let go of the Ego is to be able to lead an existential life and create one's own morality.

The members of fight club and Project Mayhem have a corporate and political obstacle that they must overcome on their existential journey. The corporate lifestyle they live is one of nihilistic neutrality. As Joe says of corporate life, "You just do your little job. Pull a lever. Push a button. You don't really understand any of it" (193). The mundane working-world is where each member of fight club and Project Mayhem comes from. They seek fight club as a way to disjoint themselves from their meaningless lives that have been formed from the onset of corporations. Tyler believes, "Advertising has these people chasing cars and clothes they don't need [...] working in jobs they hate just so they can buy what they don't need" (149).

Joe is guilty of indulging in this lifestyle. When he describes his condo, he admits to being a slave to catalogue-shopping for expensive home items from around the world. Every description of his furniture includes a brand name: Rislampa/Har paper lamps, Alle cutlery service, Klipsk shelving unit. “The people I know who used to sit in the bathroom with pornography, now they sit in the bathroom with their IKEA furniture catalogue” (43). All Joe’s life revolves around is working his day job as a recall-campaign-coordinator for a major car company so that he can purchase more materials to make him think his life will somehow be complete through material consumption.

When his condo is blown to pieces and all the furniture that he worked so hard to purchase ends up splintered and in flames on the street, he projects himself onto his possessions.

I loved my life. I loved my condo. I loved every stick of furniture. That was my whole life. Everything, the lamps, the chairs, the rugs were me. The dishes in the cabinet were me. The plants were me. The television was me. It was me that blew up (110-11).

The corporate world has made Joe and the members of fight club feel that what they own becomes not just a *part* of them, but it *becomes* them, just as they have become their possessions. As Joe acknowledges, “The things you used to own, now they own you” (44).

Fight club offers an alternative to the corporate lifestyle and helps to take the members away from the feeling that they are only as important as the materials they possess. “As long as you’re at fight club, you’re not how much money you’ve got in the bank. You’re not your job...” (143). Fight club enables these men to remember that they can be free from the world that has been designed for them, and after recognizing the absence of God, they must overcome their corporate and political obstacles.

As for the political obstacles, Project Mayhem must overcome the people who try to stop them and want to imprison them in their meaningless corporate lifestyle. When the unnamed police commissioner of Seattle recognizes that local acts of vandalism have been caused by groups of men who enjoy boxing after-hours, he sets out to crackdown on the gangs of young men and thus becomes a political threat to Project Mayhem’s purpose of resetting civilization.

To deal with the commissioner, members of Project Mayhem attack the police commissioner while he is walking his dog in the park. The

members hold the commissioner down while they remove his pants and then place a knife by his testicles. Tyler speaks to the police commissioner and explains who the members of Project Mayhem are and why they are to be left alone.

The people you're trying to step on, we're the people you depend on. We're the people who do your laundry and cook your food and serve your dinner. We make your bed. We guard you while you sleep. [...] We are cooks and taxi drivers and we know everything about you. We process your insurance claims and credit charges. We control every part of your life. We are the middle children of history, raised by television to believe that someday we'll be millionaires and movie stars and rock stars, but we won't. And we're just learning this fact (166).

Tyler acknowledges two things here. First, he acknowledges that the members of Project Mayhem know they have nothing to lose because of where they fit in the corporate lifestyle. Every job he describes is dead-end, and the members realize that because of their jobs, they really have nothing to lose, at least not to the extent of a politician who is running for office and has let a gang of young men castrate him. He also subtly tells us that these men were without parental influence as they grew up. Notice, it was not their *parents* telling them that they can grow up to be famous movie stars and rock stars, but *television* told them what they would grow up to be.

For the Underground Man, his secondary obstacle on his existential journey is to overcome the importance of social status that is imposed on him by society. Social structure becomes clear during "Apropos of the Wet Snow" in which the Underground Man attends a dinner with his co-workers. The discussion of having dinner together occurs when the Underground Man overhears a conversation between his co-workers Siminov, Ferfichkin, and Trudolyubov. They are discussing the cost of the dinner they plan to have later with their friend Zverkov, and the Underground Man promptly invites himself to join them. When he tells the men he wants to be in their company, Siminov speaks down to him, saying, "You want to come, too?" with great disdain (64). The other men immediately try to persuade the Underground Man not to join them, and Ferfichkin cites two reasons why he should not be included.

First, Ferfichkin is unsure of the Underground Man's wealth as compared to theirs, believing that he may not have enough money to cover the cost of such a meal. Secondly, he says, "But we have our own circle,

we're friends" (65). This shows the tightness of the social class that the Underground Man must overcome. The way society envelops him has made it nearly impossible for him to make a name for himself because he must overcome his perceived social status. However, during the dinner scene, the Underground Man points out the redundancy of living a lifestyle that separates everyone through social class.

When they sit down to dinner at the Hotel-Paris the next night, Zverkov interrogates the Underground Man about his salary. The Underground Man answers Zverkov, yet does not tell us the amount. However, the act of blushing upon informing the other men hints that what he makes must be very little. Ferfichkin accuses him of never being able to afford such a dinner with the salary he makes. Trudolyubov calls him "downright poor," and Zverkov noticeably glances over the Underground Man's attire and studies him with an "insolent regret" (74). Ferfichkin interjects that the men have embarrassed the Underground Man enough, to which he tells them, "My dear sir, I'll have you know that I am not embarrassed [...] do you hear, sir! I'm having dinner here, in a 'café-restaurant', at my own expense, my own and no one else's..." (74). The Underground Man is telling these men that they are wrong to accuse him of not being wealthy enough or socially adept enough to dine with them. He is currently eating at the same table in the same restaurant as them and paying the same amount for his meal as they are, and even though they are trying to break him, he feels superior to his co-workers.

The Underground Man tells us, "These oafs think they've done me an honor by giving me a place at their table; they don't realize that it's I, I, who am doing them an honor, and not they me!" (75). This begins the Underground Man's existential journey. He has already overcome the thought of God since he does not even mention Him in his narrative. Now he is working his way towards overcoming social class, noting during this dinner its redundancy and how much it confines the working man to live by certain rules and interact in a particular manner. When his co-workers try to make fun of him for his social standing, he is not ashamed because he has already realized that it is not social class that makes us what we are, but it is ourselves who make us what we are. The Underground Man retreats underground to remove himself from a society that revolves so much around class and wealth.

## Conclusion

What I have presented in this thesis is four existential fundamentals that come together to create an existential piece of literature. Through research and close readings, I have found that each existential author created protagonists and plotlines that stem from an absence of God, a physical and metaphorical journey, the use of a preacher, and an enemy of existentialism that must be overcome. If we take this paper to another level, and further authors can be researched, I am confident that this same formula will be found in any work that is deemed existential.

Based on the nature of this thesis, that is creation through destruction, I must admit that this paper ends in the height of academic irony. What you have just read is the second full edition of this paper, started from scratch. What happened is an example of tempting fate. My submersion in the literature of existentialism and nihilism catapulted me and the paper to destruction. My computer destroyed my thesis before it was sent to the printer, and my final draft was lost in the ether. I had no back-up file of my work, and it was gone, destroyed. From the ashes I was forced to recreate another draft, and by doing so created something better.

This paper was destroyed, and it partially destroyed me as well. But from that destruction, I had a choice to either stay defeated or reconstruct everything to make this paper what it is now. As you can see, in the end I looked to my own creative forces to help recreate something better out of something destructive that occurred in my life.

**Works Cited**

- Casado de Rocha, Antonio. "Disease and Community in Chuck Palahniuk's Early Fiction." Stirrings Still. 2 (2005): 65-81
- Dalton, Stuart. Existentialism Reading Notes. 18 October 2006. <<http://bluehawk.monmouth.edu/~sdalton/exist/Readnotessp05.html>>
- Dostoevsky, Fyodor. Notes from Underground. Trans. Richard Pevear and Larissa Volokhonsky. New York: Vintage Books, 1993.
- Kaufmann, Walter, ed. The Portable Nietzsche. New York: Viking Press, 1954.
- Lavrin, Janko. "A Note on Nietzsche and Dostoevsky." Russian Review. 28.2. (1969): 160-170.
- Mathews, Peter. "Diagnosing Chuck Palahniuk's Fight Club." Stirrings Still. 2 (2005): 81-105.
- Palahniuk, Chuck. Fight Club. New York: W.W. Norton & Company, 1996.
- Palahniuk, Chuck. Stranger than Fiction. New York: Doubleday, 2004.
- Sartre, Jean-Paul. Existentialism is a Humanism. Trans. Bernard Frechtman. New York: Philosophical Library, 1947.
- Trotter, F. Thomas. "Variations on the 'Death of God' Theme in Recent Theology." Journal of Bible and Religion. 33.1. (1965): 28-42.

## **THE MATHEMATICS OF GOOGLE**

Krystle Hinds

Abstract

While much has changed over the past twenty years, the changes brought by the Internet have been truly spectacular. Born only on January 1, 1983, the Internet was nonetheless being used by more than one billion people in 1996. As the Internet has grown, so have search engines. Google, one of the most important engines, uses an algorithm for searches called the Page Rank Algorithm. Like so many other search systems, Google's has had to contend with issues such as size and structure. Google's approach, however, revolutionized search capabilities. Its Page Rank system ranks a page based, in part, on its links: the number and quality of them, so that the highest ranked page is displayed at the very top of the results. This thesis focuses on the how's and why's of Google's search engine, focusing on analyzing its Page Rank's method mathematically and suggesting possibilities for improvement.

**Table of Contents**

<b>Chapter 1</b> .....	<b>102</b>
History of Internet Search Engines.	
<b>Chapter 2</b> .....	<b>105</b>
Introduction to Page Rank	
<b>Chapter 3</b> .....	<b>107</b>
Google's Mathematical Representation of the Internet	
<b>Chapter 4</b> .....	<b>113</b>
Page Rank Vector and Page Ranks	
<b>Chapter 5</b> .....	<b>117</b>
Changing the Parameters	
<b>Chapter 6</b> .....	<b>122</b>
Summary and Conclusion	
<b>Appendix A</b> .....	<b>124</b>
<b>Appendix B</b> .....	<b>129</b>
<b>References</b> .....	<b>140</b>

## Chapter 1 - History of Internet Search Engines

### Section 1 - Introduction

You need to look up information for a school project or perhaps you are looking for the phone number to a restaurant. Instead, it may be that you are simply interested in the news or financial status of the stock market. Today, millions of people turn to the Internet for these tasks, among countless others. The Internet has become society's crutch, used for nearly every aspect of life. People use it to shop, sell, advertise, communicate, learn, and handle finances. This only encompasses a short list of the Internet's capabilities and uses. Due to the growing utilization of the Internet, search engines have emerged, which include Altavista, Hotbot, Lycos, Yahoo, and Google. Their existence has become necessary, but has also been an evolution.

Surprisingly enough, January 1, 1983 was the actual birth date of the Internet. However, the Internet never reached the public eye until the 1990's. In fact, it was not until 1996 that the term "Internet" was commonly used. Since 1983, the Internet's popularity has increased in proportion to its size. In 2006, the number of web pages surpassed the one billion mark. In order for the common user to obtain all of this information that the Internet had amassed, mathematicians or computer science gurus devised search methods. In the early years of the Internet, PageRank, Hits and Salsa did not exist. Instead, methods such as nonnegative matrix factorization, latent semantic indexing, and the traditional vector space method were created and implemented. As the Internet grew in size, these methods became outdated due to many factors, but most importantly because of structure and size.

The methods mentioned above (nonnegative matrix factorization, latent semantic indexing, and the traditional vector space method) proved to be inadequate. These methods produced results to search queries based on the frequency of the search words used on a particular web page. Spammers, those trying to sell or promote a product on the Internet, would take advantage of this knowledge of searching. They would empty an entire dictionary, oftentimes more than one, onto their web page. This caused their web page to appear at the top of most search results, although the page would not be relevant to the search. The dictionaries they would empty onto a web page would be invisible to the Internet user, blending into the background of the page. As can be imagined, this proved to be frustrating and time-consuming to a user. In reality, these methods are only suitable in controlled databases, such as an online library or journal database, which will be

explained below in reference to the method of latent semantic indexing. In controlled databases, spammers do not exist. In reference to the size of the Internet, the previously used methods could not contend. The methods once used could not produce results fast enough because of the vast amount of sites, nor could they handle the every day changes of the Internet. In summary, older methods did not produce relevant timely results as a cause of the Internet's growth.

### Section II – The Traditional Vector Space Method

The traditional vector space method used to be one of the more popular search algorithms. It was actually developed in the early 1960s. This particular type of method is quite simple. It is best shown through example.

Consider the following sample of terms and documents from the Monmouth University Journal database, while noticing that the terms are truncated. That is, their multiple forms of endings are all assumed to be with the same term.

<u>Terms</u>	<u>Documents</u>
1- Educat(e, ion, or, s)	1- <i>Learning</i> Should Occur Throughout Life
2- Teach(ing, er, s, es)	2- Setting the Stage for <i>Student</i> Engagement
3- Strateg(y, ies)	3- <i>Mathematics Instructional</i> Practices & <i>Assessment</i> Accommodations by Secondary Special & General <i>Educators</i>
4- Math(ematics)	4- <i>Assessment</i>
5- Science	5- Who <i>Teaches</i> the <i>Teachers</i> ? Discourse & Policy in <i>Teacher Education</i>
6- Study(ing)	6- <i>Learning</i> from Writing in Secondary <i>Science</i>
7- Learn(ing)	7- <i>Studying</i> in Higher <i>Education</i> : <i>Student's</i> Approaches to <i>Learning</i> , Self-Regulation, & Cognitive <i>Strategies</i>
8- Instruction(al)	8- <i>Myth Education</i> : Rationale & <i>Strategies</i> for <i>Teaching</i> Against Linguistic Prejudice
9- Student(s)	
10-Assess(ment, s)	

From this, a term by document matrix, A, can be created, assuming that only titles are used when indexing and searching. Each row represents a term and each column represents a document. For instance, row 1 represents the term(s) *Educat(e, ion, or, s)* and column 1 represents the 1<sup>st</sup> document,

*Learning Should Occur Throughout Life.* If a term is present in a title of a document, the number 1 will arise. Otherwise, a 0 will occur. That being said,

$$A := \begin{bmatrix} 0 & 0 & 1 & 0 & 1 & 0 & 1 & 1 \\ 0 & 0 & 0 & 0 & 1 & 0 & 0 & 1 \\ 0 & 0 & 0 & 0 & 0 & 0 & 1 & 1 \\ 0 & 0 & 1 & 0 & 0 & 0 & 0 & 0 \\ 0 & 0 & 0 & 0 & 0 & 1 & 0 & 0 \\ 0 & 0 & 0 & 0 & 0 & 0 & 1 & 0 \\ 1 & 0 & 0 & 0 & 0 & 1 & 1 & 0 \\ 0 & 0 & 1 & 0 & 0 & 0 & 0 & 0 \\ 0 & 1 & 0 & 0 & 0 & 0 & 1 & 0 \\ 0 & 0 & 1 & 1 & 0 & 0 & 0 & 0 \end{bmatrix} \quad (1.1)$$

Many are familiar with the process of retrieving articles or titles from a database search; one simply types in key words and documents are displayed that match the key words. How those documents are chosen is a relatively simple mathematical process. Since the system already contains matrix  $A$ , that is  $A$  never changes unless a new document is entered into the database, the system then determines how relevant each document is to the search. For instance, suppose you were to search for “Instructional Strategies” from the documents listed above. A query vector,  $q$ , would be associated to this search. The vector would be made of all 0’s, except for the 3<sup>rd</sup> and 8<sup>th</sup> entries, since those are the key terms used in the search.

In all actuality, matrix  $A$  is made up of column vectors denoted by  $\vec{d}_i$ , whose  $j$ th element is the number of times term  $i$  appears in the document. Thus,  $A = [\vec{d}_1, \vec{d}_2, \dots, \vec{d}_n]$ .

Relevance of document  $i$  to query  $q$  is defined to be:

$$\partial_i = \cos \theta_i = \frac{\vec{q}^T \vec{d}_i}{\|\vec{q}\|_2 \cdot \|\vec{d}_i\|_2}. \quad (1.2)$$

For the purpose of this thesis, it is not pertinent to discuss the Frobenian norm used in (1.2). Nonetheless, it is useful to discuss the results. This vector,  $\vec{\partial}$ , would show the relevance of each document to the search.

The entry with the largest number is the most relevant. In this case, it makes sense to believe that documents 3, 7, and 8 would be among the most relevant since their titles contain the key terms used in the search.

### Section III – The Necessity of New Techniques

There are a few problems with this method. The example demonstrated was small and from a controlled database. Spamming and size were not factors in this setting, as they would be for the Internet. Additionally, this method does not take synonyms into great consideration. For example, teaching is a synonym of instruction. For the illustration above, they are treated as two different terms. Therefore, any documents with the word “teaching” in them would not show up in a search using the word “instruction.” Other methods stemmed off of the vector space method in an effort to improve results. Latent semantic indexing was a variation of the vector space method, but produced negative signs in its results, which led to difficulties interpreting meanings of relevancy. The nonnegative matrix factorization was thus devised in order to suppress those problems with negative signs; it is a variation of latent semantic indexing. However, results were not always relevant, as they depended highly on initial input values.

New methods needed to be produced. Mathematics was largely dependent on the key to their success. What emerged from the necessity of new methods were new search engines that have already been mentioned. Some of the more commonly used methods are PageRank and Hits. A third commonly mentioned method, Salsa, has been created but not yet implemented. What is known about Hits and Salsa is very minimal. Search engine algorithms are never fully published in detail and Hits and Salsa are no exception. However, main aspects of PageRank, which is used by Google, have been published, and will be the main focus of the rest of this paper.

## **Chapter 2 - Introduction to Page Rank**

### Section 1 – The Beginnings of a Billion Dollar Corporation

In 1996, Google was only a research project for two Ph.D. students at Stanford University: Larry Page and Sergey Brin. Larry and Sergey were studying computer engineering, while Sergey also had an interest in mathematics. Their research project at Stanford soon escalated. In 1998, it eventually became Google Inc. Internet users were quickly attracted to Google’s clean cut design, as well as its results. Search engines such as

AskJeeves.com (now called Ask.com) and Altavista are following Google's lead, turning to this clean cut design in order to attract more users, as Google has obviously done. Page and Brin set out with the purpose of designing a search engine that moved away from the old methods of searching for how frequently a search term is used on a page to ranking a page based on its relationship with other sites. Today, this method is labeled the Page Rank Algorithm.

In 2006, Google has clearly advanced in many aspects. Recent additions include Google Earth, Google scholar, Gmail (e-mail), blogs, directions and maps, and mobile access among many others. It has become a multi-billion dollar corporation. Aside from its own personal success, in comparison to other search engines, particularly Yahoo and MSN, Google encompasses 54% of the market share, with Yahoo having 23% and MSN 13% [W1]. Additionally, it is also reported that 80% of search referrals come from Google. Clearly, Google has dominated information retrieval.

### Section II – The Reasoning Behind PageRank

Page and Brin understood the composition of the Internet. They realized they had to contend with issues such as size and structure, just as other founders of search engines had. However, they also knew they had to change things in order to make their search better. Instead of ranking pages based on how frequently a query term is used, Page and Brin devised their own ranking scale. This particular ranking algorithm is the most popular aspect of their search engine: PageRank. PageRank ranks a page based, in part, on its links: the number and quality of them. For instance, a page with links from important pages will have a higher rank than a page with the same number of less important links. Then, for the users' benefit, the highest ranked page is displayed at the very top of the results, followed by the second highest ranked page, and so on. The idea is that the best result is displayed first, the result that is the most relevant to the search. This would then decrease the frustration Internet users have when searching for pertinent sites.

### Section III – Why Google?

One may ask oneself, why focus only on Google? The answer is simple. Google has slowly become the face and image of present day search engines. While other methods are still used, such as Yahoo and MSN, Google, for now, remains perched at the top. Its reliance on mathematics, particularly linear algebra, is both fascinating and surprising to many. To an everyday common Internet user, it is perhaps a mystery as to how and why

particular results appear the way they do. This thesis analyzes and describes how PageRank really works, in addition to determining possibilities for improvement.

### Chapter 3 - Google's Mathematical Representation of the Internet

#### Section I – Forming an Accurate Matrix Representation of the Internet

The page rank of a web page is sometimes referred to as the popularity of the page. It is also the mathematical part of the Page Rank Algorithm. Page Rank contains many components, most of which remain trade secrets of Google. However, many aspects of the mathematical part of Page Rank, perhaps the most important component, have been published and explained.

Sergey Brin and Larry Page wanted to design a search engine that allowed pages with the most important links coming to them to be the most important pages. This type of link, a link coming to a page, is called an in-link. A link coming from or out of a page is called an out-link. The page rank of each page is mostly determined from in-links. Every page has a particular number of in-links and out-links. We denote the number of out-links of page  $i$  by  $|O_i|$ . Each page is given a rank from a percentage of the rank of each in-link. In order to accomplish this, several matrices are created and altered, the first being the hyperlink matrix which demonstrates how web pages are linked on the Internet. Entries in the hyperlink matrix, denoted as  $h_{ij}$ , are computed as:

$$h_{ij} = \begin{cases} 1/|O_i| & \text{if there is a link from page } i \text{ to } j \\ 0 & \text{otherwise} \end{cases} \quad (3.1)$$

To make the Page Rank Algorithm more concrete, consider the following system illustrated in Figure 1.

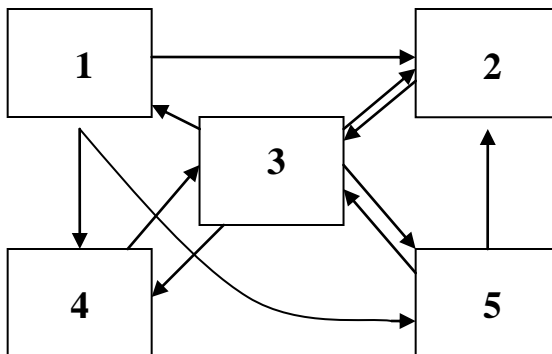

Figure 1: The figure exemplifies a link structure made up of 5 web pages. A link from one page to another is represented by the directed arrow.

For instance, page 1 has links to page 2, 4, and 5. From this system, we can create a matrix that represents the activity of hyperlinks, called  $H$ . For instance,  $h_{11}$ , which represents the first entry or the uppermost left hand corner of the matrix, would be 0, since page 1 does not have a link to itself. However, consider the value of  $h_{12}$ , the second entry in the top row. Since there is a link from page 1 to page 2 and there are a total of three out-links from page 1 (i.e.  $|O_1|=3$ ), the value of  $h_{12}$  is  $1/3$ . The rest of the entries can be computed similarly, resulting in

$$H := \begin{bmatrix} 0 & \frac{1}{3} & 0 & \frac{1}{3} & \frac{1}{3} \\ 0 & 0 & 1 & 0 & 0 \\ \frac{1}{4} & \frac{1}{4} & 0 & \frac{1}{4} & \frac{1}{4} \\ 0 & 0 & 1 & 0 & 0 \\ 0 & \frac{1}{2} & \frac{1}{2} & 0 & 0 \end{bmatrix} \quad (3.2)$$

where adding the entries of each row yields a value of one as expected. Examining the matrix further, every column illustrates how a page's rank is distributed throughout the system. From column 1, it can be determined that the page rank of page one is  $1/4^{\text{th}}$  the rank of page 3. The ranks of the remaining pages are found in a comparable manner.

Of all of the matrices,  $H$  is the best representation of the web. This is because it is the raw form of the links. The matrix is not altered in any way, completely formed from the link formation of the pages. However, this matrix has problems. In our small example, it is difficult to see the problems that may arise. Nonetheless, with respect to the Internet, this matrix would be vast and sparse. Rows with no positive values are not only plausible, but guaranteed. This type of row is a result of a dangling node and occurs when a particular webpage contains no out-links. In logical terms, this makes sense. Often, people create web pages without a concern for out-links, instead focusing on presenting information to a particular, isolated audience. A teacher, for instance, may create a website solely for his/her students. In reference to computations, though, these dangling nodes are not desirable. This is because there are many theorems and applications of stochastic

matrices, most of which will be discussed in Chapter 4. Thus, our  $H$  matrix is altered so that no dangling nodes exist.

Section II - Modifications to the  $H$  Matrix

The hyperlink matrix is altered to become a stochastic hyperlink matrix. A stochastic matrix is a matrix whose rows all add up to 1. In our example from the previous section, all of the rows do in fact sum to 1. However, if a dangling node exists, a row will sum to 0, thus not making the matrix stochastic. To make the matrix stochastic, the matrix  $S$  is created.  $S$  is denoted as:

$$S = H + a \frac{\vec{1}^T}{n} \tag{3.3}$$

where  $a$  is the column vector such that

$$a_i = \begin{cases} 1 & \text{if page } i \text{ is a dangling node} \\ 0 & \text{otherwise} \end{cases} \tag{3.4}$$

The value of  $n$  determines the size of the entries in  $S$ .

The concrete example given above does not contain any such page that would produce a dangling node. Therefore, it is revised to do so. The new system is represented below.

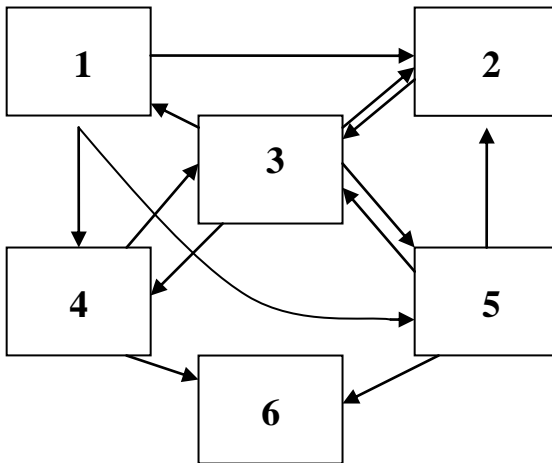

Figure 2: The figure illustrates a link structure made up of 6 web pages. A link from one page to another is represented by the directed arrow. Note that page 6 has no out-links.

Then, the new hyperlink matrix will be called  $HH$ :

$$HH := \begin{bmatrix} 0 & \frac{1}{3} & 0 & \frac{1}{3} & \frac{1}{3} & 0 \\ 0 & 0 & 1 & 0 & 0 & 0 \\ \frac{1}{4} & \frac{1}{4} & 0 & \frac{1}{4} & \frac{1}{4} & 0 \\ 0 & 0 & \frac{1}{2} & 0 & 0 & \frac{1}{2} \\ 0 & \frac{1}{3} & \frac{1}{3} & 0 & 0 & \frac{1}{3} \\ 0 & 0 & 0 & 0 & 0 & 0 \end{bmatrix}. \quad (3.5)$$

As one can easily see, there is a row of zero's, a result of a dangling node, in the last row. Obviously, this row does not sum to one, as the rows in a stochastic matrix would, so it will be altered to do so using the formula given for the  $S$  matrix. Since there are six web pages in the example, the  $n$  value will be 6. If this were an example for the entire Internet, the  $n$  value would be quite large. Then, our  $a$  looks like

$$\begin{bmatrix} 0 \\ 0 \\ 0 \\ 0 \\ 0 \\ 1 \end{bmatrix} \cdot \begin{bmatrix} \frac{1}{6} & \frac{1}{6} & \frac{1}{6} & \frac{1}{6} & \frac{1}{6} & \frac{1}{6} \end{bmatrix} \quad (3.6)$$

The matrix  $S$  would then be:

$$S := \begin{bmatrix} 0 & \frac{1}{3} & 0 & \frac{1}{3} & \frac{1}{3} & 0 \\ 0 & 0 & 1 & 0 & 0 & 0 \\ \frac{1}{4} & \frac{1}{4} & 0 & \frac{1}{4} & \frac{1}{4} & 0 \\ 0 & 0 & \frac{1}{2} & 0 & 0 & \frac{1}{2} \\ 0 & \frac{1}{3} & \frac{1}{3} & 0 & 0 & \frac{1}{3} \\ \frac{1}{6} & \frac{1}{6} & \frac{1}{6} & \frac{1}{6} & \frac{1}{6} & \frac{1}{6} \end{bmatrix}. \quad (3.7)$$

Section III – The Google Matrix

The  $S$  matrix does not guarantee convergence of the power method, a topic that will be explained more thoroughly in a later chapter. Therefore, Brin and Page introduced a primitivity adjustment [LM2]. Then, the matrix becomes primitive and stochastic. Being primitive makes it aperiodic and irreducible. In order to accomplish this, the Google matrix is then defined as

$$G = \alpha S + (1 - \alpha)E \tag{3.8}$$

where  $\alpha$  is a value between 0 and 1. It will be shown that the parameter  $\alpha$  controls the rate of convergence of the power method, an iterative technique used to solve for eigenvalues and eigenvectors of a matrix. For any matrix,  $A$ , the non-zero scalars  $\lambda$  and the vectors  $x$  that satisfy  $Ax = \lambda x$  are the eigenvalues and eigenvectors of the matrix, respectively. The power method is an important technique since solving for eigenvectors of the Google matrix leads to the Page Rank vector and ultimately the Page Ranks themselves. The last public disclosure of  $\alpha$  was set at 0.85. Additionally,  $\alpha$  must represent the frequency with which a web surfer randomly clicks from web page to web page as opposed to the frequency with which he/she manually types in the URL address for a web page. For instance, assume  $\alpha = 0.85$ . Then, this means that 85% of the time, a random web surfer follows links to move from web page to web page. The other 15% of the time, he/she manually types in the URL. This latter type of activity is evident in the equation:

$$(1 - \alpha)ev^T \tag{3.9}$$

of the Google matrix where  $ev^T = E$ , which is labeled the “fudge factor” matrix for its ability to force the power method to always converge to the dominant eigenvector. Broken down further,  $v^T$  is the personalization vector, otherwise known as the probability vector that signifies the probability of moving from one page to another. Furthermore,  $v^T > 0$ . The remaining term,  $e$  is simply a column vector of all ones. It should be noted then that  $E$  is constant. A later chapter is devoted solely to the discussion of the parameter  $\alpha$  and how it affects the rankings of web pages.

Referring back to our example, the Google matrix is formed through the construction of two matrices added together.

First, the  $S$  matrix, (3.7), is multiplied by  $\alpha$ , which looks like:

$$\begin{bmatrix} 0 & 0.2833 & 0 & 0.2833 & 0.2833 & 0 \\ 0 & 0 & 0.85 & 0 & 0 & 0 \\ 0.2125 & 0.2125 & 0 & 0.2125 & 0.2125 & 0 \\ 0 & 0 & 0.425 & 0 & 0 & 0.425 \\ 0 & 0.2833 & 0.2833 & 0 & 0 & 0.2833 \\ 0.1417 & 0.1417 & 0.1417 & 0.1417 & 0.1417 & 0.1417 \end{bmatrix}, \quad (3.10)$$

which is then added to  $(1-\alpha)\vec{e}\vec{v}^T$ , where  $1-\alpha$  is 0.15 and  $\vec{e}\vec{v}^T$  is:

$$\begin{bmatrix} \frac{1}{6} & \frac{1}{6} & \frac{1}{6} & \frac{1}{6} & \frac{1}{6} & \frac{1}{6} \\ \frac{1}{6} & \frac{1}{6} & \frac{1}{6} & \frac{1}{6} & \frac{1}{6} & \frac{1}{6} \\ \frac{1}{6} & \frac{1}{6} & \frac{1}{6} & \frac{1}{6} & \frac{1}{6} & \frac{1}{6} \\ \frac{1}{6} & \frac{1}{6} & \frac{1}{6} & \frac{1}{6} & \frac{1}{6} & \frac{1}{6} \\ \frac{1}{6} & \frac{1}{6} & \frac{1}{6} & \frac{1}{6} & \frac{1}{6} & \frac{1}{6} \\ \frac{1}{6} & \frac{1}{6} & \frac{1}{6} & \frac{1}{6} & \frac{1}{6} & \frac{1}{6} \end{bmatrix}. \quad (3.11)$$

Added together, the two matrices form the Google matrix (entries are rounded to the nearest ten-thousandth):

$$G = \begin{bmatrix} 0.025 & 0.3083 & 0.025 & 0.3083 & 0.3083 & 0.025 \\ 0.025 & 0.025 & 0.875 & 0.025 & 0.025 & 0.025 \\ 0.2374 & 0.2375 & 0.025 & 0.2375 & 0.2374 & 0.025 \\ 0.025 & 0.025 & 0.45 & 0.025 & 0.025 & 0.45 \\ 0.025 & 0.3083 & 0.3083 & 0.025 & 0.025 & 0.3083 \\ 0.1667 & 0.1667 & 0.1667 & 0.1667 & 0.1667 & 0.1667 \end{bmatrix}. \quad (3.12)$$

### Section IV - A Quick Review

One must remember that all three matrices,  $H$ ,  $S$ , and  $G$  are stochastic, while only  $S$  and  $G$  are the only matrices guaranteed to be positive.  $H$  most accurately represents the web,  $S$  forces the matrix to be positive, and  $G$  makes the matrix converge, a required criteria for finding the Page Rank vector and the Page Ranks.

In order to better understand the properties of positive, stochastic matrices, refer to Appendix A.

### Section V – A Real World Example

It is convenient to study the Page Rank method using a small 6 web page example. However, this example is not an accurate representation of the web. We use it to demonstrate the details of the Page Rank method, since it is easier to demonstrate the movement from matrix to matrix because almost any matrix using a real world example would not fit on this page. Nonetheless, we can still discuss one, as it is also beneficial to discuss how Page Rank works with a real world example.

The real world example to be discussed stems from the Math web pages at Monmouth University (<http://bluehawk.monmouth.edu/~math/> is the homepage). From this, a  $H$ ,  $S$ , and  $G$  matrix were created that accurately represented the link structure of any Monmouth University webpage ending with  $\sim math/$ . This limitation was done since the Internet encompasses billions of pages. As one might guess, the  $H$  matrix was very sparse, and the  $S$  and  $G$  matrices were very dense. Nevertheless, it is a real world example and it is later used particularly to show how different values of  $\alpha$  can change the rankings of web pages, as well as the actual page ranks.

## **Chapter 4 - Page Rank Vector and Page Ranks**

### Section I - Introduction of the Power Method

The power method, as mentioned before, is an iterative technique used to determine an eigensystem, the eigenvectors and eigenvalues, of a particular class of matrices. The proof of its convergence can be found in Appendix A. Knowing that the power method converges is very helpful. It then guarantees that the power method converges, since  $G$  follows the same properties required for the convergence of any matrix via the power method.  $G$ , in fact, converges to a vector. This vector, after normalizing, is essentially the Page Rank vector. From this vector, each web page's page rank can be determined. Below is a demonstration of this using the small example of 6

web pages introduced in Chapter 3. The algorithm for the power method is discussed in greater detail in Appendix A, which also includes a proof of its convergence. Nonetheless, the power method algorithm is

$$\lambda_1 = \frac{1}{\lambda_1^m} \lambda^{m+1} = \frac{A^{m+1} x_0 \cdot Y}{A^m x_0 \cdot Y}, \quad (4.1)$$

where,  $m \in \mathbb{N}$   $x_0$  is a linear combination of the eigenvectors of  $A$ , and  $Y$  is a vector not orthogonal to the dominant eigenvector of  $A$ .

Section II – Implementation of the Power Method (small example)

Using the power method, the page ranks of the six web pages from the example in the previous chapter can be determined. We already have the Google matrix, as observed in (3.12). From the Google matrix, the power method can be used to determine the dominant eigenvector, which in this case will be the page rank vector. Any row vector can be used to initiate the iterative power method technique. For instance, take the following random row vector:

$$x0 := [0.3 \quad -1.4 \quad 11 \quad -7 \quad 1 \quad 1.9]$$

This vector can be multiplied by the Google matrix and a vector,  $y1$ , results:

$$y1 := [2.7517 \quad 3.1200 \quad -3.4675 \quad 2.8367 \quad 2.8367 \quad -2.2775]$$

For the purpose of this thesis, all entries in vectors will be rounded to the 10,000<sup>th</sup> decimal place. The next vector is obtained from the equation  $y2 = y1G$ , where  $G$  is the Google matrix. Repeating this numerous times, we get a sequence of vectors that approach particular values:

$$y2 := [1.3573 \quad 0.6689 \quad 4.4837 \quad -0.1349 \quad -0.1349 \quad 1.8317]$$

$$y3 := [1.3573 \quad 1.0599 \quad 0.8775 \quad 1.0981 \quad 1.0981 \quad 0.3090]$$

$$y4 := [0.3752 \quad 1.0709 \quad 1.8676 \quad 0.7598 \quad 0.7598 \quad 0.9666]$$

Skipping to the sixteenth iteration:

$$y16 := [0.6256 \quad 1.0303 \quad 1.7072 \quad 0.8028 \quad 0.8028 \quad 0.8314]$$

At this point, the vector has converged to the values listed in the sixteenth iteration. Completing further iterations can be done; however, it only results in the same vector as (4.7). Therefore, it is not necessary to continue further iterations. This vector, however, is not the Page Rank vector. This vector needs to be normalized, that is adding the entries of the vector and dividing the vector by that sum. The entries in the vector add up to 5.8001. Then, the vector divided by this value results in a new vector:

$$[0.1079 \quad 0.1776 \quad 0.2943 \quad 0.1384 \quad 0.1384 \quad 0.1433]$$

This vector is now normalized such that its length equals one. This, finally, is the Page Rank vector. It represents the probability distribution since all of the entries add up to one. These ranks are relative to the pages in Figure 2. Looking further, the first entry, 0.1079 is the page rank of the first page, 0.1776 is the page rank of the second page, and so on.

Taking a different initial vector, such as

$$[1 \quad 5 \quad -0.4 \quad 0 \quad 3.2 \quad -10]$$

should result in the same answer. Repeating the process, the seventeenth iteration results in the following vector:

$$[-0.1294 \quad -0.2132 \quad -0.3532 \quad -0.1661 \quad -0.1661 \quad -0.172]$$

Normalizing it then gives

$$[0.1078 \quad 0.1777 \quad 0.2943 \quad 0.1384 \quad 0.1384 \quad 0.1433]$$

This vector looks similar to the first example, varying only slightly in the fourth decimal place. The above vector also makes sense in relation to the diagram of web pages (refer to Figure 2). It is reasonable to believe that page 3 would have the highest page rank. This page has the most activity concerning in-links. Page 1, on the other hand, has the least activity and therefore has the smallest page rank. Pages 4 and 5 have the same exact page rank. This, too, is logical, since the two pages have the same exact link structure.

As mentioned earlier, the Page Rank vector for the six page example, can be obtained from any random vector, of size  $1 \times n$ , where  $n$  is the number of web pages. While only two initial vectors have been demonstrated here, one must keep this fact in mind.

### Section III – Implementation of the Power Method (real world example)

The power method can be used for matrices of a larger size than the six page example. Our real world example actually encompasses 77 web pages. Appendix B can be referred to for details on the page ranks of every page, but it is advantageous to describe the page ranks of particular pages or groups of pages in relation to their link structure. The power method used for this example was implemented using an altered MATLAB program that can be found in [LM2], which was then used to determine the Page Rank vector.

Until further notice, let  $\alpha = 0.85$ . Then, the page with the highest rank is the home page, with a page rank value of 0.2285. The link structure of the Monmouth math pages is designed such that every page links back to the homepage. Similarly, the homepage links to several other pages. It is no surprise then that the homepage is the 1<sup>st</sup> ranked page. The lowest ranked page is “Why Math” with a value of 0.0033. This page has only one page linking to it which makes the rank very low. There are groups of pages that have the same rank. For instance, all of the adjunct faculty web pages have a page rank of 0.0043. There is a simple explanation for this. All of the adjunct faculty web pages have a similar link structure. Each have the same exact out-links and in-links. Having the same exact link structure forces these pages to have the same rank. The following is a list of the top 15 web pages with their corresponding page rank. For a complete list, refer to Appendix B.

	Page	Page Rank
	1 – Homepage	0.2285
	10 – Full Time Faculty	0.0774
	9 – Courses We Offer	0.0429
	11 – Adjunct Faculty	0.0276
	50 – Alumni Profiles	0.0257
	12 – Staff	0.0235
	28 – B. Liu	0.0216
	29 – D. Marshall	0.019
	3 – Mathematics Skills Center	0.017
0	5 – Experiential Education	0.0155
1	62 – 125/126	0.0154
2	26 – B. Gold	0.0143
3	48 – J. Toubin	0.0142
4	15 – KME	0.0136
5	4 – Undergrad. Research	0.0133

Figure 3: Web Pages with Corresponding Page Rank when  $\alpha = 0.85$ .

## Chapter 5 - Changing the Parameters

### Section I – Changing $\alpha$

Page ranks rely heavily on the parameters of the Page Rank Algorithm. One such parameter,  $\alpha$ , can be altered such that the orders of the rankings of web pages change. Although Google's last known value for  $\alpha$  was 0.85, different values are possible. For the purpose of this paper, values of 0.3, 0.5, 0.65, and 0.9 replaced 0.85 in order to demonstrate the movement of the ranked pages. The following tables show the top 15 ranked web pages, and corresponding rank for each of these values of  $\alpha$  listed above, using the real world example of Monmouth's mathematics website. For a complete listing, refer to Appendix B. After each table is a brief commentary on how some of the top 15 web pages changed compared to the Google value of  $\alpha = 0.85$ .

	Page	Page Rank
1	1 – Homepage	0.1062
2	10 – Full Time Faculty	0.0366
3	9 – Courses We Offer	0.031
4	11 – Adjunct Faculty	0.0238
5	62 – 125/126	0.0168
6	50 – Alumni Profiles	0.0159
7	28 – B. Liu	0.0157
8	12 – Staff	0.0151
9	29 – D. Marshall	0.014
10	25 – J. Coyle	0.0135
11	26 – B. Gold	0.0134
12	53 – 050	0.0131
13	68 – 221	0.0131
14	61 – 120	0.0127
15	3 – Mathematics Skills Center	0.0124

Figure 4: Web Pages with Corresponding Page Rank when  $\alpha = 0.3$ .

In this example, new pages entered the top 15 such as page 25, 53, 68, and 61. Page 62 moved from the 11<sup>th</sup> to the 5<sup>th</sup> ranked position. Other pages such as 4, 5, and 15 were not in the top 15 this time.

	Page	Page Rank
1	1 – Homepage	0.1552
2	10 – Full Time Faculty	0.0514
3	9 – Course We Offer	0.0391
4	11 – Adjunct Faculty	0.0279
5	50 – Alumni Profiles	0.0184
6	62 – 125/126	0.0176
7	28 – B. Liu	0.0173
8	12 – Staff	0.0172
9	29 – D. Marshall	0.0155
10	26 – B. Gold	0.0138
11	25 – J. Coyle	0.0134

12	3 – Mathematics Skills Center	0.0132
13	5 – Experiential Education	0.0126
14	53 – 050	0.0124
15	68 - 221	0.0123

Figure 5: Web Pages with Corresponding Page Rank when  $\alpha = 0.5$ .

When  $\alpha = 0.5$ , page 62 jumped up 5 positions to be the 6<sup>th</sup> highest ranked page. However, page 3 dropped 3 positions to be ranked 12<sup>th</sup>. New pages to enter the top 15 were 25, 53, and 68. Pages to leave the top 15 were 4, 15, and 48.

	Page	Page Rank
1	1 – Homepage	0.1878
2	10 – Full Time Faculty	0.0624
3	9 – Courses We Offer	0.0427
4	11 – Adjunct Faculty	0.0292
5	50 – Alumni Profiles	0.0209
6	12 – Staff	0.0193
7	28 – B. Liu	0.0188
8	62 – 125/126	0.0173
9	29 – D. Marshall	0.0169
10	3 – Mathematics Skills Center	0.0144
11	26 – B. Gold	0.0141
12	5 – Experiential Education	0.0135
13	25 – J. Coyle	0.0133
14	48 – J. Toubin	0.0123
15	2 - About	0.0123

Figure 6: Web Pages with Corresponding Page Rank when  $\alpha = 0.65$ .

Again, page 62 moved up in ranking, becoming the 8<sup>th</sup> ranked position when  $\alpha = 0.65$ . Page 25 and 2 were added to the top 15, with pages 4 and 15 leaving the top 15. Page 5 dropped two positions from its 10<sup>th</sup> ranked spot when  $\alpha = 0.85$ .

	Page	Page Rank
1	1 – Homepage	0.2386
2	10 – Full Time Faculty	0.0812
3	9 – Courses We Offer	0.0419
4	50 – Alumni Profiles	0.0274
5	11 – Adjunct Faculty	0.0264
6	12 – Staff	0.025
7	28 – B. Liu	0.0225
8	29 – D. Marshall	0.0196
9	3 – Mathematics Skills Center	0.018
10	5 – Experiential Education	0.0162
11	48 – J. Toubin	0.015
12	62 – 125/126	0.0146
13	26 – B. Gold	0.0142
14	15 – KME	0.0141
15	4 – Undergrad. Research	0.0137

Figure 7: Web Pages with Corresponding Page Rank when  $\alpha = 0.9$ .

Although 0.9 is a very close value to 0.85, there are still significant changes among the ranked pages. Page 50 moved up 1 position to become the 4<sup>th</sup> highest ranked page. Page 48 also moved up in ranking, while page 26 moved down one position.

Overall, the top 3 ranked pages were never altered. They remained strong in their ranks. However, the ranks of the other 12 positions changed from one  $\alpha$  to the next. The true value of  $\alpha$  at the particular moment is unknown. However, it is now known that Google can manipulate  $\alpha$  to change the orders of page ranks. Even a small change in  $\alpha$  can have big effects. When  $\alpha$  experienced an increase of a mere five hundredths to become 0.9, pages changed rankings and not only in the top 15 as noted above. Looking at all of the pages, the last ranked page when  $\alpha = 0.85$  was page 49. When  $\alpha = 0.9$ , this page moved up 11 spots. This movement is large enough to cause a web page to move to a different page of search results in Google, as each page of search results contains 10 results. Since most Internet users only look at the first few pages of results, this is very important.

## Section II – Changing the Probability Vector

Like  $\alpha$ , changes in the probability vector, also sometimes called the personalization vector, can also alter the order of ranked pages. To remind the reader, the probability vector is introduced when there are dangling nodes. If there are no dangling nodes, the probability vector is insignificant. Unfortunately, the Monmouth mathematics website has no dangling nodes. Therefore, altering the probability vector will have no effect on the ranks of the pages. However, referring back to our 6 web-page example, we can alter the probability vector and see how the pages change in ranking. A copy of the 6 web-page example is below.

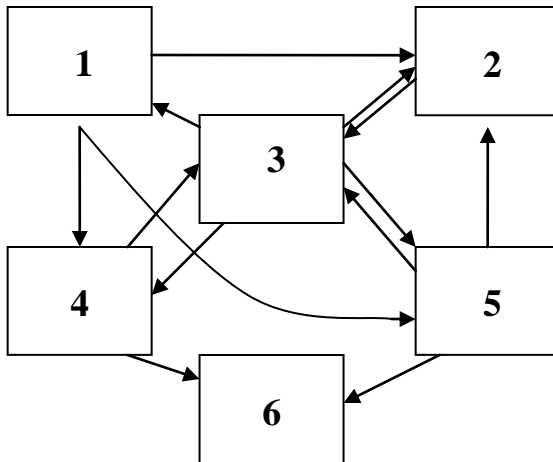

Figure 8: The figure illustrates a link structure made up of 6 web pages. A link from one page to another is represented by the directed arrow. Note that page 6 has no out-links.

Note that before, the probability vector was a vector with every entry as  $\frac{1}{n}$ , where  $n$  is the number of web pages. However, the only restriction the probability vector actually has is that it must sum to 1, or in

mathematical terms, be stochastic. Therefore, there are an endless number of possibilities for any probability vector, despite length. The chart below characterizes some different probability vectors, including the original of  $\frac{1}{n}$  for every entry, with the corresponding order of ranked pages. The page ranks and orders were obtained using the same MATLAB program as before.

Vector	Probability	Page Rank Vector	Ordering of Pages
	$(\frac{1}{6}, \frac{1}{6}, \frac{1}{6}, \frac{1}{6}, \frac{1}{6}, \frac{1}{6})$	(0.1079,0.1776,0.2943,0.1384,0.1384,0.1434)	(3,2,6,4,5,1)
	$(0,0,0,0,\frac{1}{2},\frac{1}{2})$	(0.0794,0.1565,0.2559,0.1019,0.1927,0.2137)	(3,6,5,2,4,1)
	$(\frac{1}{2}, \frac{1}{2}, 0,0,0,0)$	(0.1353,0.2091,0.2914,0.1253,0.1253,0.1137)	(3,2,1,4,5,6)
	(1,0,0,0,0)	(0.1821,0.1702,0.2636,0.1326,0.1326,0.1189)	(3,1,2,4,5,6)
	(0,0,0,0,1,0)	(0.0844,0.1713,0.2796,0.1083,0.2223,0.134)	(3,5,2,6,4,1)

Figure 10: Chart comparison of different probability vectors and their resulting page ranks.

The original rank had page 3 as the highest ranked page. Despite several attempts to “de-rank” page 3, the attempts proved unsuccessful. However, it was possible to make the last ranked page, page 1, as well as the second to last ranked page, page 5, the 2<sup>nd</sup> highest in two individual attempts.

Thus, not only is it possible to change the ordering of ranked pages by altering the  $\alpha$  value, but it is also achievable by changing the probability vector.

### Chapter 6 - Summary and Conclusion

PageRank relies heavily upon mathematics. It is the mathematics that allows the flexibility of the orders of ranked pages. Google does not publish its  $\alpha$  and probability vector daily, or every year for that matter. It is impossible to know if Google is manipulating different pages to be at a higher rank than others through the mathematics it uses. However, it is possible for this to occur. The extent of this flexibility may not even be

known to the general public, or mathematicians, as it may not have been published yet by Google. There have been others who have written papers accusing Google of accepting monetary contributions in exchange for higher page ranks. This has not been proven true, but the thought exists.

Despite this accusation, Google continues to grow every day. Its stock increases, as does its number of users and on-line options. Its success is undeniable. However, there seems to be a side of Google that is unknown and mysterious. It is a side that one hopes can remain honest and true, and uncorrupted by the opportunity for greed.

**Appendix A**

The purpose of Appendix A is to investigate the properties of positive stochastic matrices, including proving the convergence of the power method, which is used to determine page ranks. These proofs and explanations are necessary for the complete understanding and application of the Page Rank algorithm.

**Lemma 1:** For any matrix  $P > 0$  and vector  $x \geq 0$  with  $x \neq 0$ , we have  $Px > 0$ .

Proof:

Any positive matrix multiplied by a vector with at least one positive entry and all other entries non-negative, will always result in a positive vector, since multiplication and addition of positive numbers is always positive. Thus,  $Px > 0$  with the assumed conditions. ♦

**Lemma 2:** If  $A > 0$  for any  $n \times n$  matrix  $A$ , then (i)  $\rho(A) \in \sigma(A)$  and (ii)  $Ax = \rho(A)x$  implies  $A|x| = \rho(A)|x|$ , where  $\rho(A) := \max\{|\lambda| : \lambda \in \sigma(A)\}$  and  $\sigma(A)$  is the set of all eigenvalues, called the spectrum of  $A$ .

Proof:

We may assume that  $\rho(A) = 1$ . If  $\rho(A) \neq 1$ , the matrix  $A$  can be scaled such that  $\rho(A) = 1$ . Since  $\rho(A) = 1$ ,  $Ax = \pm x$ .

If  $(\lambda, x)$  is any eigenpair of  $A$  such that  $|\lambda| = 1 = \rho(A)$ , then

$$|x| = |\lambda| |x| = |\lambda x| = |Ax| \leq A \|x\| = A|x| \tag{1}$$

and so

$$|x| \leq A|x|. \tag{2}$$

Let  $z = A|x|$ , which means  $z \geq 0$ , and define  $y = z - |x|$ . Then,

$$y = z - |x| = A|x| - |x| \geq 0 \tag{3}$$

which implies  $y \geq 0$ .

Suppose  $y \neq 0$ . Then, from Lemma 1,  $Ay > 0$  and  $z > 0$ . Therefore,  $\exists$  an  $\epsilon > 0$  such that  $Ay > \epsilon z$ .

Then,

$$A(z - |x|) > \epsilon z \tag{4}$$

$$Az - A|x| > \epsilon z \tag{5}$$

$$Az - z > \epsilon z \tag{6}$$

$$Az > \epsilon z + z \tag{7}$$

$$Az > z(\varepsilon + 1) \tag{8}$$

And finally

$$\frac{A}{\varepsilon + 1} z > z. \tag{9}$$

We then define  $B = \frac{A}{1 + \varepsilon}$ . Then,  $Bz > z$ .

If we multiply both sides by B, the following is true since  $B > 0$ :

$$B^2 z > Bz > z \tag{10}$$

$$B^3 z > B^2 z > z \tag{11}$$

⋮

$$B^k z > Bz > z. \tag{12}$$

However,  $\lim_{k \rightarrow \infty} B^k z = 0$ . This then implies that  $z \leq 0$ . This contradicts the fact that  $z > 0$ . Then, this implies our supposition that  $y \neq 0$ , must be false. Therefore,  $y = 0$  which shows the following:

$$0 = y = A|x| - |x| \implies A|x| = |x|. \tag{13}$$

Thus, we have proved that  $A|x| = |x|$ . Recall that  $Ax = \pm x$ . We have shown that this implies  $A|x| = |x|$ . Thus, this proves both facts, (i) and (ii). ♦

**Comment 1:** It is implied from Lemma 2 that if  $Ax = \rho(A)x$  then either  $x > 0$  or  $x < 0$ .

**Theorem 1:** If  $(\lambda, y)$  is an eigenpair for a matrix  $A > 0$  such that  $y > 0$ , then  $\lambda = \rho(A)$ .

Proof:

Lemma 2 guarantees that there is an eigenvector associated with  $\rho(A)$ . Let  $x$  be a non-negative eigenvector of  $A^T$  that corresponds to  $\rho(A^T)$ . Since  $x$  is an eigenvector of  $A^T$ ,  $x^T$  must be a left eigenvector of  $A$ . This means that

$$\rho(A)x^T = x^T A \tag{1}$$

Multiplying by  $y$  gives

$$\rho(A)x^T y = x^T A y = \lambda x^T y \tag{2}$$

since  $(\lambda, y)$  is an eigenpair for  $A$ . Thus, since  $x^T \geq 0$ ,  $y > 0$ , and  $x^T y > 0$ ,

$$\rho(A) = \lambda. \tag{3}$$

In other words, it can be concluded that any positive eigenvector has the eigenvalue with greatest magnitude associated with it. From Lemma 2, we also know that  $\rho(A) \in \sigma(A)$ . Thus, this implies that  $\lambda > 0$ . ♦

**Theorem 2:** For any matrix  $A > 0$  whose rows sum to  $\alpha$ ,  $\rho(A) = \alpha$ , where  $\alpha \in \mathbb{R}$ .

Proof:

Let  $e > 0$  be a column vector of all 1's. Then,  $Ae = \alpha e$ . Using Theorem 1, we can conclude that  $\alpha = \rho(A)$  since  $e > 0$ . ♦

**Corollary 1:** The dominant eigenvalue of any positive row stochastic matrix is 1.

Proof:

Applying Theorem 2 to any positive row stochastic matrix, it can be determined that the dominant, or maximum, eigenvalue is 1. Because the matrix is row stochastic, every row adds to  $\alpha = 1$ . However, according to the theorem above,  $\alpha = \rho(A)$ . Thus, 1 is the dominant eigenvalue of any row stochastic matrix. ♦

**Theorem 3:** If  $A > 0$ , then the algebraic multiplicity of  $\rho(A)$  is 1.

Proof:

We may assume that  $\lambda = \rho(A) = 1$ , as in the proof of Lemma 2. For  $A > 0$ , it is known that the algebraic and geometric multiplicities of  $\rho(A)$  are equal. Suppose the geometric multiplicity of  $\rho(A)$  is  $m$ . That means there are  $m$  linearly independent eigenvectors associated with  $\lambda = 1$ . Let  $x$  and  $y$  be a pair of linearly independent eigenvectors associated with  $\lambda = 1$ . Therefore,  $x \neq \alpha y \quad \forall \alpha \in \mathbb{C}$ .

Since  $y \neq 0$ , there is a non-zero component  $y_i$  of  $y$ . Let  $z = x - (x_i / y_i)y$ . Then,  $z \neq 0$ ,  $z_i = 0$ , and  $Az = z$ . From Lemma 2,  $|Az| = |z|$ . However, since  $z_i = 0$ , this contradicts Lemma 1. Therefore,  $\lambda$  could not have two linearly independent eigenvectors. As a result,  $\lambda$  has geometric multiplicity of 1. Thus, algebraic multiplicity is 1. ♦

**Theorem 4 (Convergence of the Power Method):** Suppose that  $A$  has  $n$  eigenvalues,  $\{\lambda_1, \lambda_2, \dots, \lambda_n\}$ , associated with  $n$  linearly independent eigenvectors,  $\{V_1, V_2, \dots, V_n\}$ . Moreover, suppose that precisely one eigenvalue,  $\lambda_1$ , is largest in magnitude such that  $|\lambda_1| > |\lambda_2| \geq \dots \geq |\lambda_n|$ . Then,  $A^m x_0$  converges to a multiple of  $V_1$ , as  $m$  increases and  $x_0$  is any vector in  $\mathbb{R}^n$ .

Proof:

From the given suppositions,  $x_0$  can be written as a linear combination of the eigenvectors of  $A$ :

$$x_0 = c_1V_1 + c_2V_2 + \dots + c_nV_n = \sum_{i=1}^n c_iV_i \tag{1}$$

where  $\{c_1, c_2, \dots, c_n\} \subseteq \mathbb{R}$ . Multiplying both sides by some power of  $A$ , call it  $m$ , then results in:

$$A^m x_0 = c_1\lambda_1^m V_1 + c_2\lambda_2^m V_2 + \dots + c_n\lambda_n^m V_n = \sum_{i=1}^n c_i\lambda_i^m V_i \tag{2}$$

since  $A^m V_i = \lambda_i^m V_i$ , for  $i$  from 1 to  $n$ . Dividing both sides by  $\lambda_1^m$ , where  $\lambda_1^m \neq 0$ , produces

$$\frac{1}{\lambda_1^m} A^m x_0 = c_1V_1 + \left(\frac{\lambda_2^m}{\lambda_1^m}\right) c_2V_2 + \dots + \left(\frac{\lambda_n^m}{\lambda_1^m}\right) c_nV_n \tag{3}$$

which equals

$$\frac{1}{\lambda_1^m} A^m x_0 = c_1V_1 + \left(\frac{\lambda_2}{\lambda_1}\right)^m c_2V_2 + \dots + \left(\frac{\lambda_n}{\lambda_1}\right)^m c_nV_n. \tag{4}$$

Since the eigenvalues were ordered with respect to magnitude, it is known that

$$\left(\frac{\lambda_2}{\lambda_1}\right)^m \geq \left(\frac{\lambda_3}{\lambda_1}\right)^m \geq \dots \geq \left(\frac{\lambda_n}{\lambda_1}\right)^m. \tag{5}$$

The largest term then governs how fast the remaining terms approach 0. Thus, the rate of convergence depends on how fast  $\left(\frac{\lambda_2}{\lambda_1}\right)^m$  goes to 0.

With  $\frac{\lambda_2^m}{\lambda_1^m} c_2V_2 + \dots + \frac{\lambda_n^m}{\lambda_1^m} c_nV_n \rightarrow 0$ , as  $m \rightarrow \infty$ , this then implies that

$$\frac{1}{\lambda_1^m} A^m x_0 \rightarrow c_1V_1 \tag{6}$$

as  $m \rightarrow \infty$  which is a scalar multiple of the dominant eigenvector. ♦

However, the power method can also be used to determine the dominant eigenvalue of the system. According to (6), it is also true that

$$\frac{1}{\lambda_1^{m+1}} A^{m+1} x_0 = c_1 V_1 \tag{7}$$

as  $m \rightarrow \infty$  since  $m+1 > m$ .

If  $c_1 \neq 0$ , then an approximation of  $\lambda_1$  can be obtained as follows.

Taking the dot product of (6) and (7) with any vector  $Y$  not orthogonal to  $V_1$  results in

$$\frac{1}{\lambda_1^m} (A^m x_0 \cdot Y) \rightarrow c_1 V_1 \cdot Y \tag{8}$$

and

$$\frac{1}{\lambda_1^{m+1}} (A^{m+1} x_0 \cdot Y) = c_1 V_1 \cdot Y . \tag{9}$$

Therefore, by the transitive property,

$$\frac{1}{\lambda_1^m} (A^m x_0 \cdot Y) = \frac{1}{\lambda_1^{m+1}} (A^{m+1} x_0 \cdot Y) . \tag{10}$$

Then,

$$\lambda_1 = \frac{1}{\lambda_1^m} \lambda_1^{m+1} = \frac{A^{m+1} x_0 \cdot Y}{A^m x_0 \cdot Y} . \tag{11}$$

Thus, using  $\lambda_1$ , the dominant eigenvalue can be found. Substituting  $\lambda_1$  into (6), a scalar multiple of the dominant eigenvector is obtained. ♦

With respect to Google, we know that  $\lambda_1 = 1$  from Theorem 2. Therefore, using equation (6) and substituting  $\lambda_1 = 1$ , we have

$$A^m x_0 = c_1 V_1 \tag{12}$$

where  $c_1 V_1$  is essentially the Page Rank vector for a particular query search.

**Appendix B**

Appendix B allows for a complete comparison and analysis of the different parameter values vs. page ranks and the order of ranked pages.

**Web Page Names:**

The following is a list of numbered web pages. Refer to the number of the page when determining their ranks in later sections of the Appendix. The pages are in order from the highest ranked page to the lowest ranked page. Their page ranks are listed respectively next to each web page.

**Page Ranks when alpha = 0.3:**

1	0.1062
10	0.0366
9	0.031
11	0.0238
62	0.0168
50	0.0159
28	0.0157
12	0.0151
29	0.014
25	0.0135
26	0.0134
53	0.0131
68	0.0131
61	0.0127
3	0.0124
5	0.0121
48	0.0121
2	0.0121
24	0.012
46	0.0119
33	0.0118
30	0.0117
35	0.0115
15	0.0114
4	0.0114

**Page Ranks when alpha = 0.5:**

1	0.1552
10	0.0514
9	0.0391
11	0.0279
50	0.0184
62	0.0176
28	0.0173
12	0.0172
29	0.0155
26	0.0138
25	0.0134
3	0.0132
5	0.0126
53	0.0124
68	0.0123
2	0.0121
48	0.0119
61	0.0116
15	0.0115
33	0.0115
4	0.0114
24	0.0114
46	0.0114
20	0.0112
19	0.0109

34	0.0113	30	0.0108
55	0.0113	35	0.0106
69	0.0112	34	0.0103
20	0.0112	8	0.0102
19	0.0111	13	0.0102
57	0.011	14	0.0102
70	0.0109	16	0.0102
51	0.0107	17	0.0102
52	0.0107	18	0.0102
8	0.0106	21	0.0102
13	0.0106	22	0.0102
14	0.0106	55	0.0101
16	0.0106	57	0.0099
17	0.0106	69	0.0097
18	0.0106	51	0.0096
21	0.0106	52	0.0096
22	0.0106	70	0.0094
58	0.0106	32	0.0091
32	0.0105	60	0.0089
60	0.0105	23	0.0087
56	0.0105	56	0.0087
23	0.0102	58	0.0087
6	0.0102	47	0.0086
47	0.0102	6	0.0084
73	0.0101	36	0.0084
77	0.0101	73	0.0083
36	0.01	77	0.0083
66	0.0098	27	0.0082
72	0.0098	31	0.0082
27	0.0098	37	0.0079
31	0.0098	38	0.0079
37	0.0098	39	0.0079
38	0.0098	40	0.0079
39	0.0098	41	0.0079
40	0.0098	42	0.0079

41	0.0098	43	0.0079
42	0.0098	44	0.0079
43	0.0098	45	0.0079
44	0.0098	66	0.0078
45	0.0098	72	0.0078
7	0.0097	7	0.0075
49	0.0095	49	0.0072
54	0.0094	54	0.0072
59	0.0094	59	0.0072
63	0.0094	63	0.0072
64	0.0094	64	0.0072
65	0.0094	65	0.0072
67	0.0094	67	0.0072
71	0.0094	71	0.0072
74	0.0094	74	0.0072
75	0.0094	75	0.0072
76	0.0094	76	0.0072

**Page Ranks when alpha = 0.65:**

1	0.1878
10	0.0624
9	0.0427
11	0.0292
50	0.0209
12	0.0193
28	0.0188
62	0.0173
29	0.0169
3	0.0144
26	0.0141
5	0.0135
25	0.0133
48	0.0123

**Page Ranks when alpha = 0.85:**

This is the last public disclosure of  $\alpha$  .

1	0.2285
10	0.0774
9	0.0429
11	0.0276
50	0.0257
12	0.0235
28	0.0216
29	0.019
3	0.017
5	0.0155
62	0.0154
26	0.0143
48	0.0142
15	0.0136

2	0.0123	4	0.0133
15	0.012	20	0.013
4	0.0119	25	0.013
20	0.0117	2	0.0128
46	0.0115	19	0.0126
53	0.0114	46	0.0125
33	0.0113	8	0.0112
19	0.0113	13	0.0112
68	0.0113	14	0.0112
24	0.0109	16	0.0112
8	0.0104	17	0.0112
13	0.0104	18	0.0112
14	0.0104	21	0.0112
16	0.0104	22	0.0112
17	0.0104	33	0.0109
18	0.0104	24	0.0099
21	0.0104	51	0.0092
22	0.0104	52	0.0092
61	0.0102	68	0.0092
30	0.01	53	0.0091
35	0.0099	30	0.0089
34	0.0094	35	0.0088
51	0.0091	34	0.0082
52	0.0091	57	0.0076
57	0.009	61	0.0074
55	0.0089	32	0.007
69	0.0084	47	0.0069
32	0.0082	55	0.0069
70	0.0081	23	0.0067
60	0.0079	36	0.0066
23	0.0078	60	0.0065
47	0.0077	69	0.0064
36	0.0075	27	0.0063
27	0.0073	31	0.0063
31	0.0073	70	0.0063

---

56	0.0072	6	0.0057
6	0.0071	73	0.0053
58	0.007	77	0.0053
73	0.007	56	0.0049
77	0.007	58	0.0045
37	0.0064	37	0.0043
38	0.0064	38	0.0043
39	0.0064	39	0.0043
40	0.0064	40	0.0043
41	0.0064	41	0.0043
42	0.0064	42	0.0043
43	0.0064	43	0.0043
44	0.0064	44	0.0043
45	0.0064	45	0.0043
66	0.0062	66	0.0039
72	0.0062	72	0.0039
7	0.0059	7	0.0038
54	0.0056	54	0.0034
59	0.0056	59	0.0034
63	0.0056	63	0.0034
64	0.0056	64	0.0034
65	0.0056	65	0.0034
67	0.0056	67	0.0034
71	0.0056	71	0.0034
74	0.0056	74	0.0034
75	0.0056	75	0.0034
76	0.0056	76	0.0034
49	0.0055	49	0.0033

**Page Ranks when alpha = 0.9:**

1	0.2386	68	0.0085
10	0.0812	53	0.0083
9	0.0419	34	0.0079
50	0.0274	57	0.0071
11	0.0264	47	0.0069
12	0.025	32	0.0068
28	0.0225	23	0.0065
29	0.0196	61	0.0065
3	0.018	36	0.0064
5	0.0162	55	0.0063
48	0.015	27	0.0062
62	0.0146	31	0.0062
26	0.0142	60	0.0062
15	0.0141	69	0.0058
4	0.0137	70	0.0058
20	0.0135	6	0.0054
2	0.013	73	0.0048
19	0.013	77	0.0048
25	0.013	56	0.0042
46	0.013	37	0.0037
8	0.0115	38	0.0037
13	0.0115	39	0.0037
14	0.0115	40	0.0037
16	0.0115	41	0.0037
17	0.0115	42	0.0037
18	0.0115	43	0.0037
21	0.0115	44	0.0037
22	0.0115	45	0.0037
33	0.0107	58	0.0037
24	0.0095	66	0.0033
51	0.0095	72	0.0033
52	0.0095	7	0.0032
30	0.0086	49	0.0028
35	0.0086	54	0.0027
		59	0.0027

**Graph of Page Ranks vs. Web Pages:**

Graph 1:

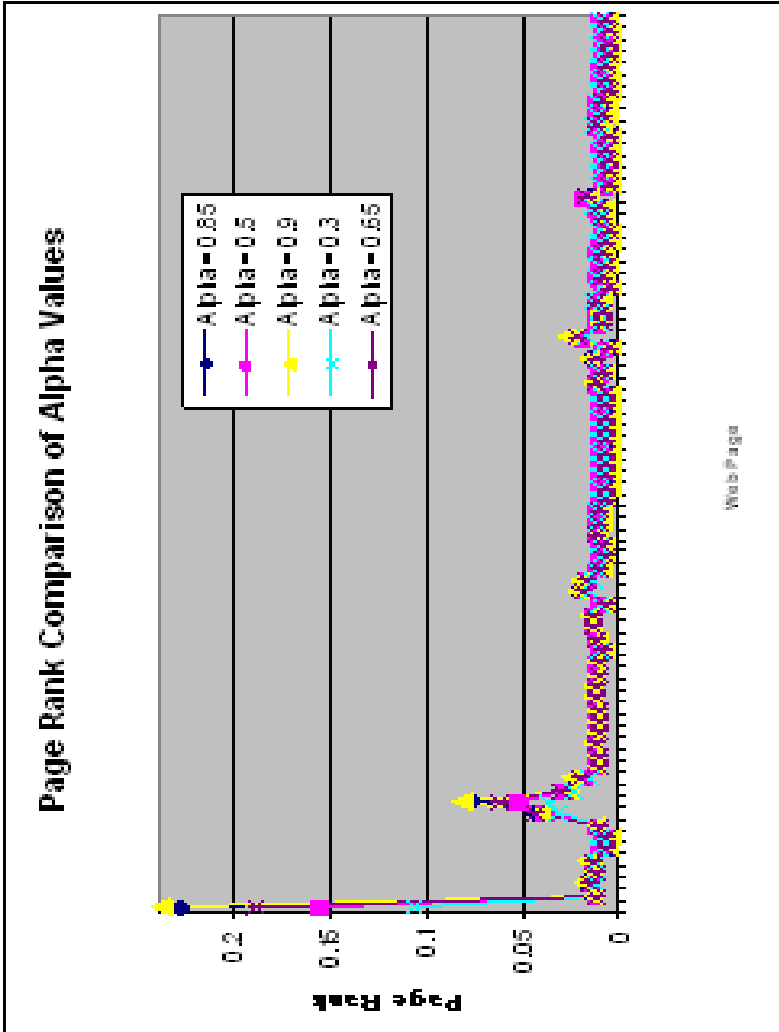

Graph 2:

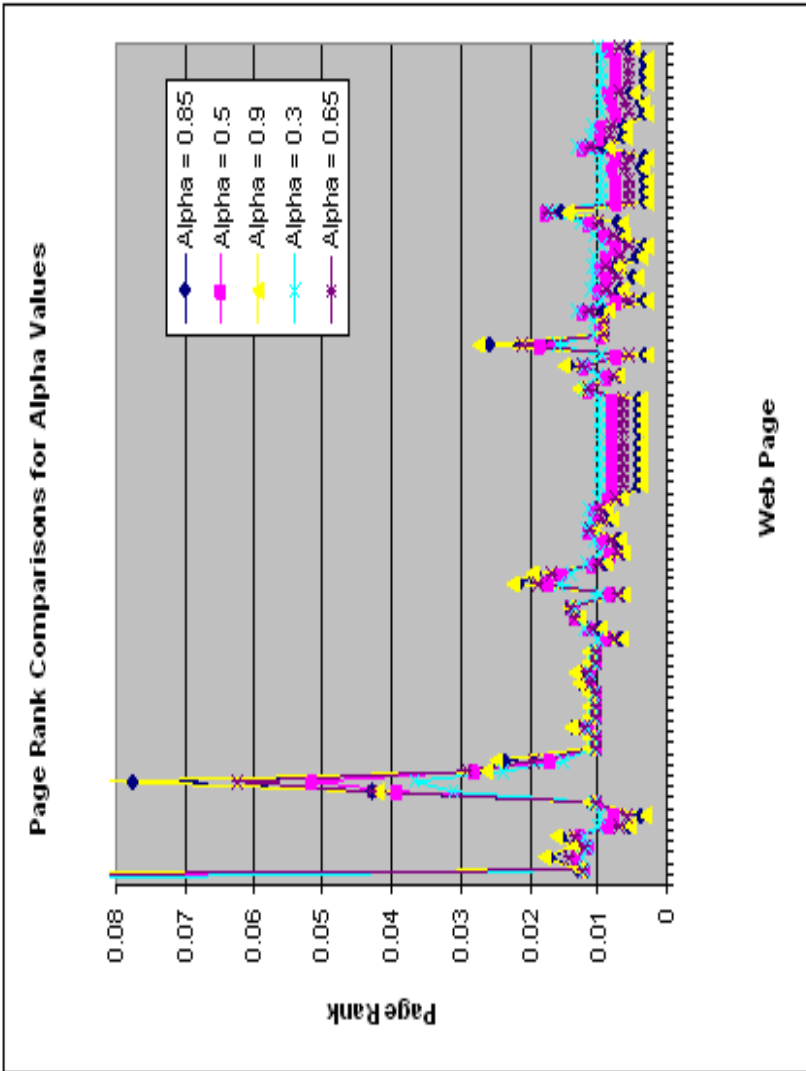

Graph 3:

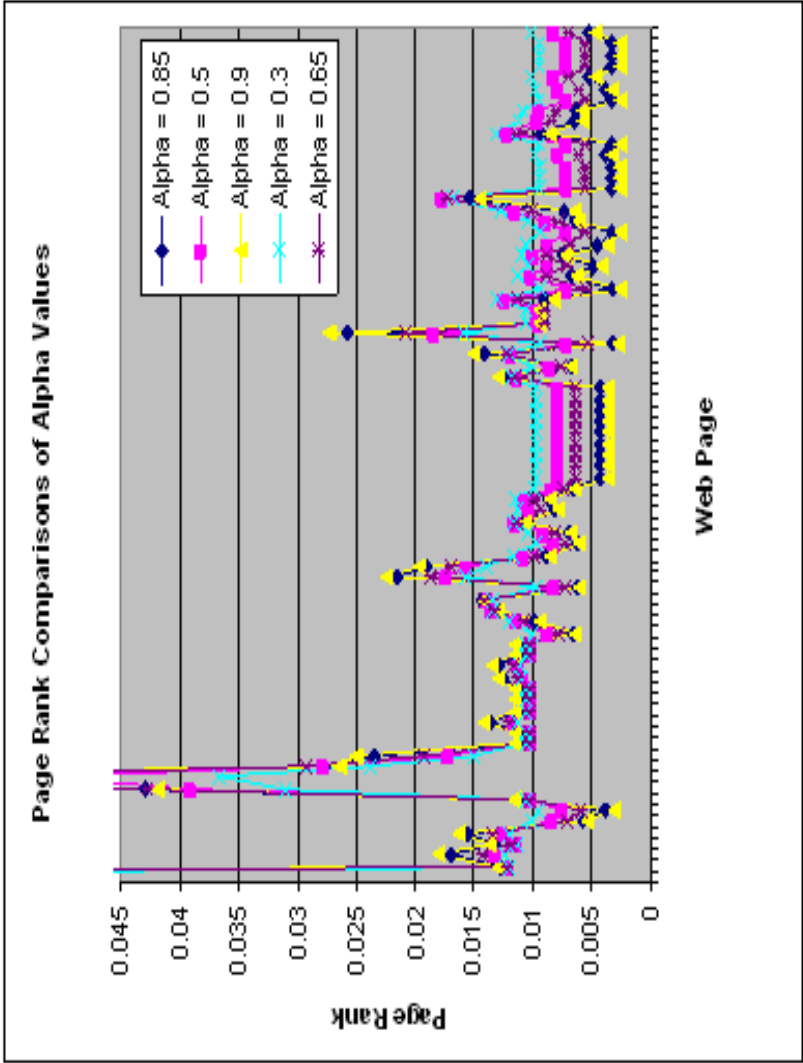

A List of Web Pages by Number of Page and its Corresponding Name

1- Homepage index	45- D. Wacha
2- About	46- D. Brown
3- Mathematics Skills Center	47- L. Horowitz
4- Undergraduate research project	48- J. Toubin
5- Experiential Education	49- Why Math
6- Honors Theses	50-Alumni Profiles
7- Dept. Mission Statement	51- S. Woelfer
8- Department Newsletter	52- S. Lance
9- Courses We Offer	53- 050
10- Full Time Faculty	54- 100
11- Adjunct Faculty	55- 101
12- Staff	56- 105
13- Math Colloquium	57- 109
14- Prospective Students	58- 115
15- KME	59- 116
16- Degree Programs	60- 117/118
17- Mathematics Placement Exam	61- 120
18- Gateway Exams	62- 125/126
19- Career Resources	63- 131L-133L
20- Mathematics Computer Lab	64- 151
21- Computer Classrooms	65- 203/204
22- MU Tester	66- 211
23- R. Bastian	67- 219
24- B. Bodner	68- 221
25- J. Coyle	69- 225
26- B. Gold	70- 314
27- K. Krishan	71- 317
28- B. Liu	72- 319/320
29- D. Marshall	73- 410
30- S. Marshall	74- 411
31- R. Pawloski	75- 413
32- L. Penge	76- 415
33- T. Smith	77- 419
34- G. Swartz	
35- S. Wen	
36- R. Kuntz	
37- A. Allen	

- 38- J. Brower
- 39- L. Dietrich
- 40- W. Epstein
- 41- G. Ford
- 42- D. Menist
- 43- K. Poracky
- 44- A. Wacha

\*\*This list is up to date as of 12/31/2006.

**References**

- [B1] Bretscher, Otto. Linear Algebra with Applications. (2005), Prentice Hall, NJ.
- [BF2] Burden, R. and Faires, D. Numerical Analysis. (2004), Brooks-Cole.
- [C1] Caufield, James. “Where did Google Get its Value?” Libraries and the Academy. 5.4(2005): 555-572.
- [C2] Clausen, Andrew. “How Much Does it Cost to Buy a Good Google PageRank?” 2003. University of Pennsylvania. 10 April 2006. [http://www.econ.upenn.edu/~clausen/ideas/google/google\\_subvert.pdf](http://www.econ.upenn.edu/~clausen/ideas/google/google_subvert.pdf)
- [D1] Deo, Narsingh and Gupta, Pankaj. World Wide Web: A Graph-Theoretic Perspective. 2001. University of Central Florida. 13 March 2006.
- [F1] Farahat, A., Lofaro, T., et al. “Authority Rankings from Hits, Pagerank, and Salsa: Existence, Uniqueness, and Effect of Initialization.” Society for Industrial and Applied Mathematics. 27.4 (2006): 1181-1201.
- [H1] Haveliwala, Taher and Kamvar, Sepandar. “The Second Eigenvalue of the Google Matrix.” 2003. Stanford University. 10 April 2006. <http://scholar.google.com/scholar?hl=en&lr=&q=cache:YfGTRw9g4RYJ:nlp.stanford.edu/pubs/secondeigenvalue.pdf+%22the+second+eigenvalue+of+the+google+matrix+%22+>
- [K1] Kamvar, Sepandar and Haveliwala, Taher. “The Condition Number of the Page Rank Problem.” Stanford University. 10 April 2006. <http://nlp.stanford.edu/pubs/condition.pdf>
- [LM1] Langville, Amy and Meyer, Carl. “Deeper Inside Page Rank.” Internet Mathematics. 1.3 (2006): 335-380.
- [LM2] Langville, Amy and Meyer, Carl. Google’s PageRank and Beyond: The Science of Search Engine Rankings. Princeton University Press. June 2006.

- [LM3] Langville, Amy and Meyer, Carl. “Information Retrieval and Web Search.” 2006. College of Charleston. 10 April 2006.  
[http://scholar.google.com/scholar?hl=en&lr=&q=cache:2\\_Ys-jdMJbQJ:meyer.math.ncsu.edu/Meyer/PS\\_Files/HLA.pdf+%22information+retrieval+%22+langville+and+meyer](http://scholar.google.com/scholar?hl=en&lr=&q=cache:2_Ys-jdMJbQJ:meyer.math.ncsu.edu/Meyer/PS_Files/HLA.pdf+%22information+retrieval+%22+langville+and+meyer).
- [M1] Meyer, Carl. Matrix Analysis and Applied Linear Algebra. Society for Industrial and Applied Mathematics. 2000.
- [R1] Rogers, Ian. “The Google Pagerank Algorithm and How it Works”. 2002. IPR Computing Ltd. 10 April 2006.  
<http://www.iprcom./papers/pagerank/>
- [W1] Wikipedia Foundation. “Google”, Wikipedia.com, Dec. 1, 2006. Available at: <http://en.wikipedia.org/wiki/Google> . [12/1/2006].